



DURESCA®

DTOI RIP Bushings, 36 - 300kV

Transformer to Air IEC 60137-2008

 **MOSER GLASER**
Current and voltage – our passion

DRILCO

Swiss quality combined with global experience



Features

Dry-type RIP Insulation

Moser Glaser researched a way to increase the dielectric characteristics of its High Voltage equipment. As a result Moser Glaser invented the Epoxy Resin Impregnated Paper (RIP) technology in 1958.

With more than 50 years of experience in development of the ERIP technology, Moser Glaser offers transformer bushings DURESCA® DTOI from 36 to 300kV.

The insulation lays directly on the conductor or tube and consists of crepe paper dried under vacuum and impregnated with epoxy resin. Conductive grading layers are embedded during the winding of the insulation for the best field control. This guarantees the highest operational and human safety.

- A strong moisture barrier prevents any contamination or moisture ingress.
- Moser Glaser design does not use any oil; DTOI are completely dry and free of partial discharge.
- DTOI bushings can be applied at any position from 0° to 90° from vertical and allow for safe horizontal transport and storage.

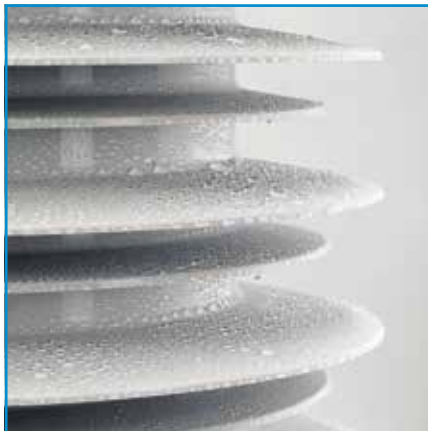

Silicone housing

- Moser Glaser pioneered the standardization of Silicone Rubber Insulators on Bushings, bringing a high level in safety and reliability to the Electric Utility industry and increasing the performance of the bushing in heavily polluted environments.
- Weight reduced as well as flexible sheds, increase its tolerance to vandalism, or earthquakes. No risk of porcelain break during shipping or handling; no collateral damage.

Replacement bushings

- In addition to the standard range, our design, combined with our production process, allows a wide flexibility and adaptability to provide tailor-made solutions.

Moser Glaser can interchange a wide variety of bushings designs. This allows the customer to replace existing OIP bushings with the RIP technology. The supply chain is simplified as the silicone molding operation is done in-house, Moser Glaser can offer short lead-times for its standard range of product.



Standard ratings DTOI 36 – 123kV

Standard	IEC 60137-2008														
Frequency	50 / 60 Hz														
Altitude of erection	< 1000 m														
Ambiant Temperature	Class 3: - 40°C...+ 40°C														
Angle of Mounting	0 – 90°														
Highest Voltage	Um	kV	36	52	72.5	123									
Dry Power Frequency voltage withstand	Up	kV	77	105	155	255									
Lightning Impulse withstand voltage	U Bil	kV	170	250	325	550									
Rated Current	Ir	A	2000 2500 3150	1600 2000 2500 3150	800 1250 1600 2000 2500	800 1250 1600 850 2000									
Connection to transformer*			FC* FC* FC*	FC* FC* FC* FC*	DL* SC* FC* FC* FC*	DL* SC* FC* FC* FC*									
Specific creepage distance		mm mm/kV	1116 31	1612 31	2248 31	3813 31									
Cantilever test load (min) (class II IEC 60137)		N	2000 2000 3150	1600 2000 2500 3150	2000 2000 2000 3150 3150	3150 3150 3150 4000 4000									

*DL = Draw-Lead / *SC = Split-Conductor / *FC = Fix-Conductor

Dimensions

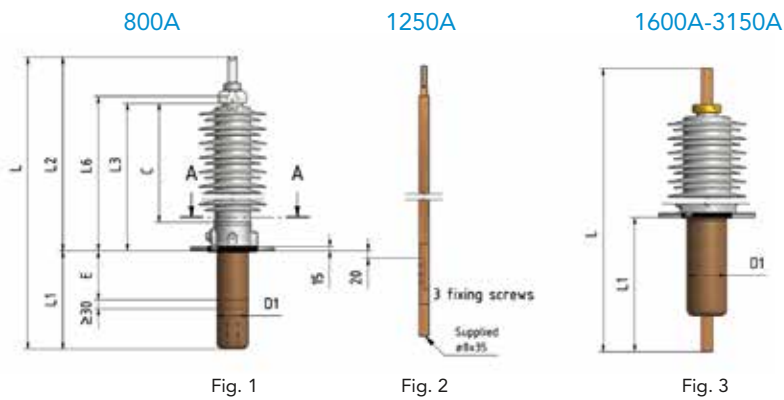

Top dimensions

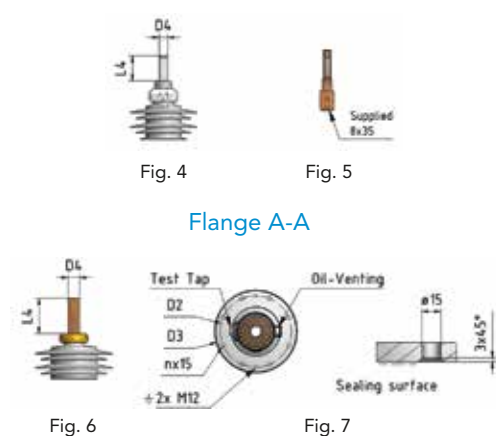

Bottom detail

800A



Cable Connection DL
Fig. 8

1250A



Removable Copper Conductor SC
Fig. 9

1600A-3150A



Fixed Copper Conductor FC
Fig. 10

DTOI 36 and 52kV

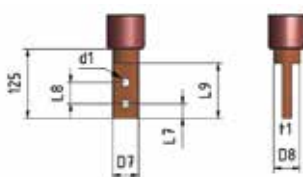

Fixed Copper Conductor
Fig. 11

Um	Ir	d1	D7	D8max	L7	L8	L9	t1
36	2000	18	51*	55	20	40	85	20
	2500	18	51	60	20	40	85	20
	3150	18	74	80	20	40	85	30
52	1600	14	37	42	20	40	85	20
	2000	18	51	55	20	40	85	20
	2500	18	62	65	20	40	85	20
	3150	18	85	90	20	40	85	30

* 56.6 for E300 and E500mm

Dimensions (mm)

Type	E	C	L	L1	L2	L3	L4	L6	D1max	D2	D3	nx15	D4	D6	D7
DТОI 36-2000	0	350	850	245	605	450	125		80	185	225	6	50		51
	300		1150	545											
	500		1450	745											
DТОI 36-2500	0	350	850	245	605	450	125		80	185	225	6	50		51
	300		1150	545											56.6
	500		1450	745											56.6
DТОI 36-3150	0	350	850	245	605	450	125		109	250	290	8	60		74
	300		1150	545											
	500		1450	745											
DТОI 52-1600	0	450	970	265	705	550	125		80	185	225	6	40		37
	300		1270	565											
	500		1470	765											
DТОI 52-2000	0	450	970	265	705	550	125		109	250	290	8	50		51
	300		1270	565											
	500		1470	765											
DТОI 52-2500	0	450	970	265	705	550	125		109	250	290	8	60		62
	300		1270	565											
	500		1470	765											
DТОI 52-3150	0	450	970	265	705	550	125		141	250	290	8	60		85
	300		1270	565					141						
	500		1470	765					109						
DТОI 72.5-800	0	600	1035	175	860	700	80	715	80	185	225	6	30	35.7	
	300		1335	475											
	500		1535	675											
DТОI 72.5-1250	0	600	1035	175	860	700	80		80	185	225	6	30		
	300		1335	475											
	500		1535	675											
DТОI 72.5-1600	0	600	1155	300	855	700	125		80	185	225	6	40		40
	300		1455	600											
	500		1655	800											
DТОI 72.5-2000	0	350	1155	300	855	700	125		109	250	290	8	40		40
	300		1455	600											
	500		1655	800											
DТОI 72.5-2500	0	600	1155	300	855	700	125		109	250	290	8	60		60
	300		1455	600											
	500		1655	800											
DТОI 72.5-3150	0	600	1155	300	855	700	125		141	250	290	8	60		60
	300		1455	600											
	500		1655	800											
DТОI 123-800	0	1050	1650	340	1310	1150	80	1165	109	250	290	8	30	35.7	
	300		1950	640											
	500		2150	840											
DТОI 123-1250	0	1050	1650	340	1310	1150	80		109	250	290	8	30		
	300		1950	640											
	500		2150	840											
DТОI 123-1600	0	1050	1770	465	1305	1150	125		141	250	290	8	40		40
	300		2070	765											
	500		2270	965											
DТОI 123-2000	0	1050	1770	465	1305	1150	125		141	250	290	8	40		40
	300		2070	765					141						
	500		2270	965					109						
DТОI 123-2500	0	1050	1770	465	1305	1150	125		190	290	335	12	60		60
	300		2070	765					146						
	500		2270	965					146						

Standard ratings DTOI 145 – 300kV

Standard		IEC 60137-2008															
Frequency		50 / 60 Hz															
Altitude of erection		< 1000 m															
Ambiant Temperature		Class 3: – 40°C...+ 40°C															
Angle of Mounting		0 – 90°															
Highest Voltage	Um kV	145				170				245				300			
Dry Power Frequency voltage withstand	Up kV	305				355				505				505			
Lightning Impulse withstand voltage	U Bil kV	650				750				1050				1050			
Switching Impulse dry / wet /	U Sil kV									850				850			
	U Sil kV													850			
Rated Current	I _r A	800 1250 1600 2000 2500				800 1250 1600 2000 2500				800 1250 1600 2000				800 1250 1600 2000			
Connection to transformer*		DL* SC* FC* FC* FC*				DL* SC* FC* FC* FC*				DL* SC* FC* FC* FC*				DL* SC* FC* FC* FC*			
Specific creepage distance	mm	4495				5270				7595				9300			
	mm/kV	31				31				31				31			
Cantilever test load (min) (class II IEC 60137)	N	3150 3150 3150 4000 4000				4000 4000 4000 5000 5000				4000 4000 4000 5000				4000 4000 4000 5000			

*DL = Draw-Lead / *SC = Split-Conductor / *FC = Fix-Conductor

Dimensions

800A

1250A

1600A-3150A

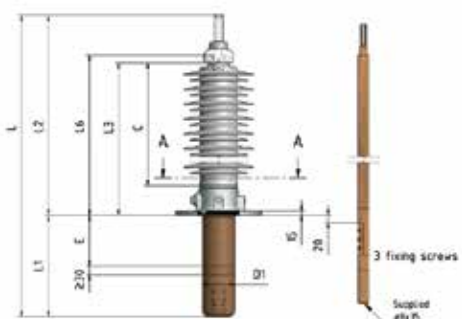

Fig. 12



Fig. 13

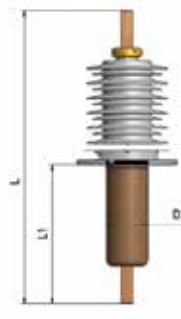

Fig. 14

Top dimensions



Fig. 15



Fig. 16

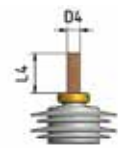

Fig. 17

Flange A-A

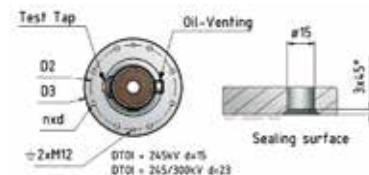

Fig. 18

Bottom detail

800A



Cable Connection DL
Fig. 19

1250A



Removable Copper Conductor SC
Fig. 20

1600A-3150A



Fixed Copper Conductor FC
Fig. 21

Dimensions (mm)															
Type	E	C	L	L1	L2	L3	L4	L6	D1max	D2	D3	n(d)	D4	D6	D7
DIOI 145 – 800	0	1250	1900	390	1510	1350	80	1365	141	250	290	12	30	35.7	
	300		2200	690					109						
	500		2400	890					109						
DIOI 145 – 1250	0	1250	1900	390	1510	1350	80		141	250	290	12	30		
	300		2200	690					109						
	500		2400	890					109						
DIOI 145 – 1600	0	1250	2020	515	1505	1350	125		141	250	290	12	40		40
	300		2320	815					141						
	500		2520	1015					109						
DIOI 145 – 2000	0	1250	2020	515	1505	1350	125		190	250	290	12	40		40
	300		2320	815					141						
	500		2520	1015					141						
DIOI 145 – 2500	300	1250	2320	815	1505	1350	125		190	290	335	12	60		60
	500		2520	1015					146						
DIOI 170 – 800	0	1450	2160	450	1710	1550	80	1565	141	290	335	12	30	35.7	
	300		2460	750											
	500		2660	950											
DIOI 170 – 1250	0	1450	2160	450	1710	1550	80		141	290	335	12	30		
	300		2460	750											
	500		2660	950											
DIOI 170 – 1600	0	1450	2280	575	1705	1550	125		190	290	335	12	40		40
	300		2580	875					146						
	500		2780	1075					141						
DIOI 170 – 2000	0	1450	2280	575	1705	1550	125		190	290	335	12	40		40
	300		2580	875											
	500		2780	1075											
DIOI 245 – 800	0	2310	3250	620	2630	2460	80	2480	190	400	450	12	30	50	
	300		3550	920											
	500		3750	1120											
DIOI 245 – 1250	0	2310	3250	620	2630	2460	80		190	400	450	12	30		
	300		3550	920											
	500		3750	1120											
DIOI 245 – 1600	0	2310	3370	745	2625	2460	125		190	400	450	12	40		40
	300		3670	1045											
	500		3870	1245											
DIOI 245 – 2000	300	2310	3670	1045	2625	2460	125		190	400	450	12	40		40
	500		3870	1245											
DIOI 300 – 800	0	2310	3250	620	2630	2460	80	2480	190	400	450	12	30	50	
	300		3550	920											
	500		3750	1120											
DIOI 300 – 1250	0	2310	3250	620	2630	2460	80		190	400	450	12	30		
	300		3550	920											
	500		3750	1120											
DIOI 300 – 1600	0	2310	3370	745	2625	2460	125		190	400	450	12	40		40
	300		3670	1045											
	500		3870	1245											
DIOI 300 – 2000	300	2310	3670	1045	2625	2460	125		190	400	450	12	40		40
	500		3870	1245											

Accessories

Test Tap

All Bushings are equipped with a 2kV test tap. Used to test the capacitance C , partial discharge pC and the dissipation factor $\tan \delta$.

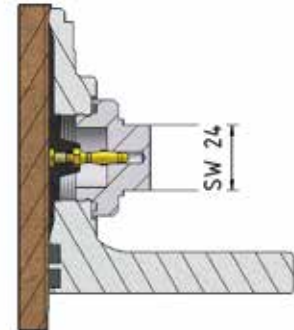

Arcing Horns made of CrNi Steel

Arcing horns are used to protect the bushing from damage in case of flashover. L distance can be adapted to customer needs.

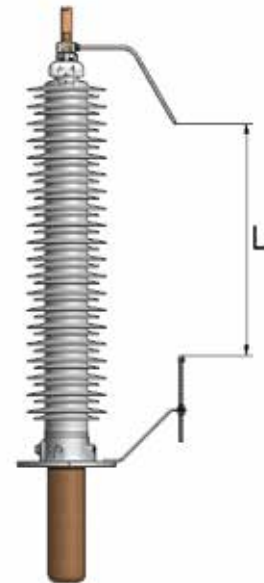

External Shield

On customer requirement, the Fix-conductor version can be equipped with an external shield.



Example of Nameplate marking



Type:DT0I/ $U_m=52kV/AC=105kV/BIL=250kV/I_r=800A/f_r=50Hz$

No:EA2011xxx.xx.x/m=42kg/ $\alpha=90^\circ$

Installation

Oil side detail for Draw Lead and Split Conductor application

800A

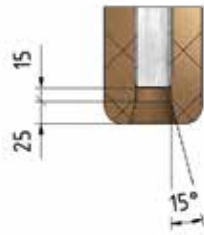

1250A

Conductor with split inside the Moser Glaser bushing tube (CLC/TS 504 58)

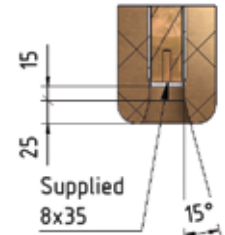

Minimum distance to earthed parts

The distance to the earthed parts is depending of Voltage, transformer tank design as well as oil condition and quality.

This distance is according to the recommendation of the standard CLC / TS 50458, lower distance can be covered after approval from Moser Glaser.

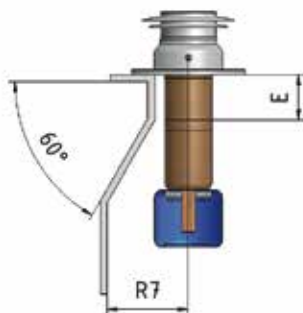
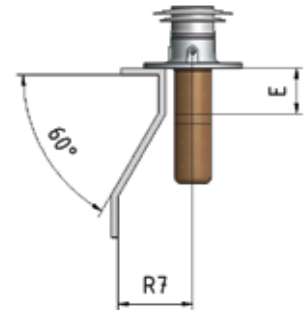

R7 Min (mm)

Um (kV)	I _r (A) 1250	1600	2000	2500	3150
52		100	100	100	120
72.5	120	120	120	120	140
123	160	160	160	160	
145	230	230	230	230	
170	230	260	260	260	
245	325	325	325		
300	325	325	325		

Testing

Routine Tests

Each DTOI is tested in accordance with the bushings specification IEC 60137-2008.

Type Tests

Our DTOI range of products have been type tested, reports are available on request.



Special Tests

Moser Glaser has performed some special tests to figure out its excellent design, below two examples some others are available on request.

Special Tests 1

Continuous operation test to on a DTOI 123kV bushing.
Simulating 30 years operation time.
Total of 50 000 lifting's at -30°C and $+50^{\circ}\text{C}$. Followed by routine test and dry lightning impulse withstand test (BIL) according IEC 60137.



Special Test 2

«Cook Test» on 145kV Bushing. 42 hours at $+98^{\circ}\text{C}$ with 1% salt solution followed by dry lightning impulse withstand test (BIL).

Target: To ensure that no humidity is taken up by the direct cast silicone insulator and RIP insulating body.



Checklist for DURESCA® bushing Transformer-Outdoor

Electrical data

Standard: IEC IEEE FSK Other _____

Rated voltage _____ kV

Bushing Insulation Level

Lightning impulse withstand voltage 1.2/50µs (BIL) _____ kV

Dry power frequency voltage withstand (AC) _____ kV

Switching Impulse (SIL) _____ kV

Rated frequency _____ Hz

Rated current _____ A

Connections

Altitude < 1000m Other _____ m

Ambient temperature -40°C / +40°C Other _____ °C

Oil temperature 90°C Other _____ °C

Creepage distance 31 mm/kV

Cantilever test load Acc to the IEC 60137 class II

Seismic conditions

Angle of mounting 0-90° Other _____ °

Horizontal acceleration _____ m/s²

Vertical acceleration _____ m/s²

Design

Top terminal material



- Aluminium
- Copper
- Silver Plated Copper
- Tin Plated Copper

CT extension E



- 0mm
- 300mm
- 500mm
- _____ mm

Arcing horns

- Yes
- No

Oil side shield



- Yes
- No

Commercial

Company name _____

Contact _____

Phone number _____

Email _____

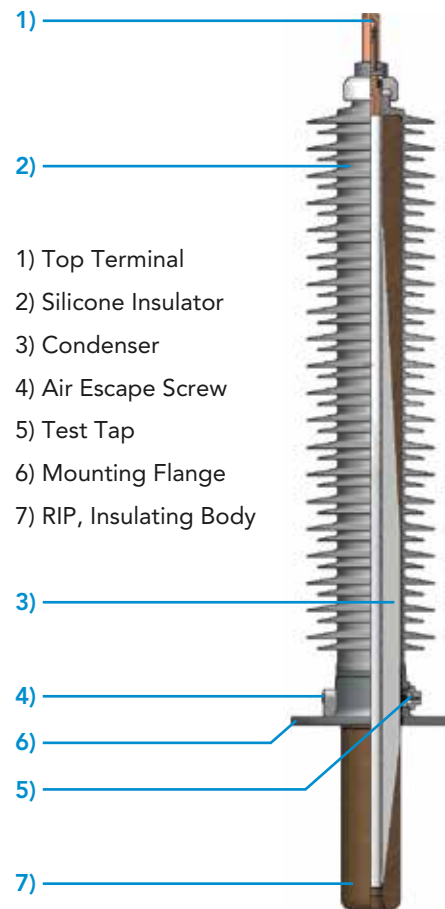

- 1) Top Terminal
- 2) Silicone Insulator
- 3) Condenser
- 4) Air Escape Screw
- 5) Test Tap
- 6) Mounting Flange
- 7) RIP, Insulating Body



Power Transformer equipped with Moser Glaser Bushings

Quantity _____ pieces

Delivery EXW FOB

Term DAP Other _____

Destination _____

DURESCA®
Busbar system



TIRESCA®
Busbar system



LINK®
SF₆ insulatet busbar system



DURESCA®
Wall bushings



DURESCA®
Transformer bushings



MOSER GLASER

Current and voltage – our passion

MGC Moser-Glaser Ltd.
Lerchenweg 21
4303 Kaiseraugst
Switzerland

☎ +41 61 467 61 11
✉ info@mgc.ch
🌐 www.mgc.ch

Member of PFIFFNER Group

This document has been drawn up with the utmost care. We can not however, guarantee that it is entirely complete, correct or up-to-date.

© Copyright Moser Glaser, Subject to change without notice. 2017.06

Represented by:

DRILCO

Avda. Somosierra 22, E-6 y 7
E-28703 S. S. de los Reyes (Madrid) España
Tel.: +34 916 591 900 • drilco@drilco.net • www.drilco.net