

DRILCO

YASH
HIGHVOLTAGE



Voltage Ratings: 52-145 kV

Current Rating: up to 5000 Amps

CONDENSER BUSHING

Salient Features

- ❏ Oil impregnated paper condenser
- ❏ Standards : IEC/ANSI/IEEE
- ❏ Low dielectric loss
- ❏ Partial discharge free
- ❏ Excellent mechanical strength
- ❏ Good seismic and short circuit withstand
- ❏ Easy clean alternate sheds
- ❏ Explosion proof lower end insulator
- ❏ All parts suitable for class E
- ❏ Operation (-) 25 ~ (+) 70°C

CONDENSER BUSHING

Expertise for Reliability

Yash is an independent manufacturer of transformer bushings. Our core strength is design and development of products which meet and exceed customer expectations. We are resourceful internally and externally, but ensure a continual process of improvement of our products and business process.

Design

Condenser Bushing is built up about a strong center pipe. The pipe is insulated with superior grade electrical kraft paper, which is finely graded to ensure uniform field distribution across and along the projected air end as well as immersed transformer end.

The other parts are assembled about the center pipe, pre-stressed with a spring assembly to safely operate against -25 to +700 C. The spring load ensure product resistant to impacts due to earthquake and short circuit forces.

Insulation

The major insulation, the kraft paper, wound around the center pipe, is dried under heat and vacuum to remove moisture and slowly impregnated with processed transformer oil. Oil in the bushing is provided with an expansion space with N₂ gas. Oil sight glass is provided to show the presence of oil.

An insulated test tap is provided on the mounting flange to facilitate direct connection to the condenser core to check the soundness of the insulation periodically. A cap is provided to positively earth the tap to ground, after measurement.

Bottom Electrode

The bottom electrode is provided to reduce electrical stress inside transformers. The insulated lead can be tapered in to the electrode. Vital dimensions of the electrodes are given in the dimensional table. 145 kV has a detachable electrode as detailed below. (Fig.1)

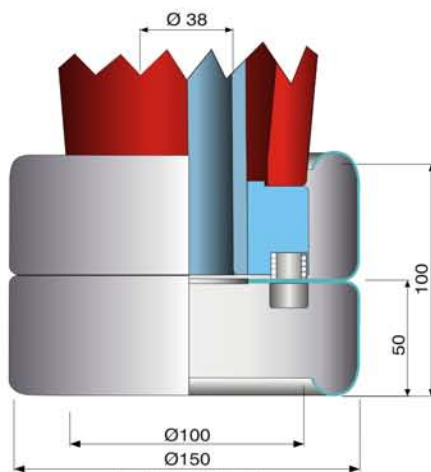

(Fig.1) 145 kV Electrode

Testing

The Condenser Bushings are subjected to a number of assurance tests during the process and on completion of manufacturing . Tests are conducted as per the latest release of IEC-60137.

Each bushing is tested for tan delta, capacitance and partial discharge before and after dry power frequency over voltage test. Pressure test is conducted on completed bushing at elevated temperature for 12 hrs.

Type tests are conducted on prototypes as per IEC-60137. Temperature rise was conducted with bushing oil end kept at 60°C above ambient.

Connection

Most popular is draw lead, where the transformer lead is drawn up through the center pipe and fixed with top terminal.

Bushing is provided with a thimble on which flexible copper lead can be soldered or blazed.

Table below gives general guidance for flexible lead/rod sizes of high conductivity copper sections. 20% allowance shall be taken above transformer full load current to conform to the over loading requirement of IEC-60345.

Current Carrying Lead Sizes

Current Amp.	Lead mm ²	Rod dia mm	Short ckt in kA	
			1 sec	2 sec
150	50	-	4.8	3.4
210	70	-	6.7	4.8
285	95	-	9.1	6.5
425	150	-	14.4	10.2
460	185	-	17.5	12.6
570	285	-	26	19.4
800	-	20	30	21
1250	-	30	70	50

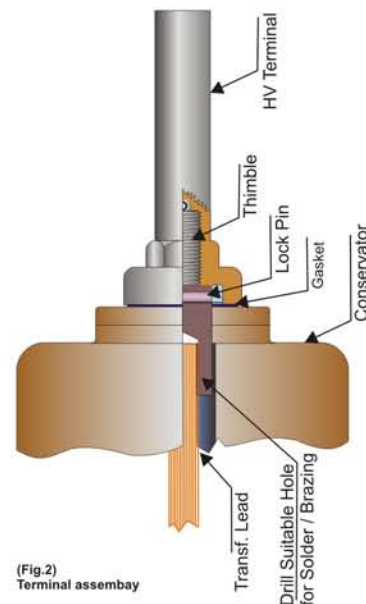

(Fig.2) Terminal assembly

Technical Particulars

Dimensional Table all dimensions are in mm

Rated Voltage	kV	52	72.5	123	145
Basic Insulation Level	kVp	250	350	550	650
AC Test Voltage	kV	105	155	255	305
Creepage Length	mm	1300	1810	3075	3625
CT Space	L6	0, 100, 300			
Oil End Length	L1	300+L6	300+L6	500+L6	500+L6
Air End Length	L2	850	1050	1480	1680
Total Length	L	1150+L6	1350+L6	1980+L6	2180+L6
Conservator Height	L3	320	320	360	360
Flash Over Length	L4	460	660	1050	1250
Mounting Flange	L5	70	70	70	70
Bottom Electrode	L7	60	60	100	100
Lead Entry	L8	30	30	50	50
Oil End Diameter	D1	115	115	160	160
Bore of Pipe	D2	34	34	38	38
Bottom Electrode	D3	100	100	140	140
Conservator Diameter	D4	180	180	220	220
Flange PCD	D6	185	185	290	290
Flange OD	D7	225	225	335	335
Mounting Holes	d*n	15*6	15*6	15*12	15*12
Flange Thickness	T	16	16	16	16
Shed Diameter		240	240	265	265

Kindly refer to contract drawings for specific details. Other creepage lengths and BCT provisions can be offered as special requirements. Draw lead for current up to 800 Amps. Draw rod for 800 to 1250 Amps.

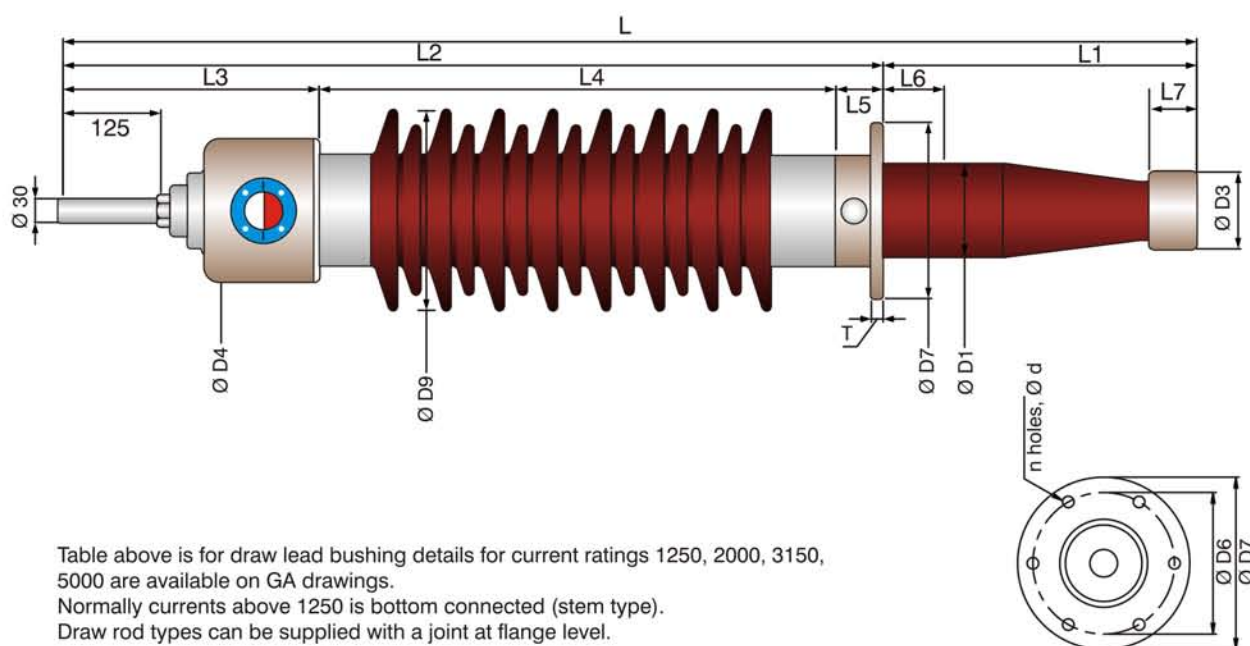

Table above is for draw lead bushing details for current ratings 1250, 2000, 3150, 5000 are available on GA drawings. Normally currents above 1250 is bottom connected (stem type). Draw rod types can be supplied with a joint at flange level.

Other Products & Services from YASH

- 🚩 High Current Bushings up to 25000 Amps
- 🚩 FRP Cylinder for transformer Applications
- 🚩 Spare Bushings to retrofit with any reputed make
- 🚩 Refurbish used bushings to "AS GOOD AS NEW"



*Owing to continuous innovations, details on this catalogue are subject to change without prior notice. This catalogue should only be regarded as a guide and is intended for information only.