

















LEGEND

GENERIC		
 Accuracy (%)	 Torque & Angle	 Digital Display
 Single Scale	 Dual Scale	 Multi Scale
 Calibration Certificate	 UKAS Accredited Certification	 IP Rated
 Bluetooth Enabled	 Case Included	

SCREWDRIVERS & TORQUE WRENCHES		
 Ratchet	 Torque Handle	 Fixed
 Adjustment Lock	 Declaration of Conformance	 Calibration Certificate

MANUAL TORQUE MULTIPLIERS		
 Adjustable Reaction	 Anti Wind-up Ratchet	

POWERED TORQUE TOOLS		
 Adjustable Reaction	 2 Speed	 Air Consumption - litres/sec
 Lifting Attachment	 Bi-Directional	

TORQUE MEASUREMENT INSTRUMENTS		
 Multi Transducers	 Back-up Data	

HARSH ENVIRONMENT INSTRUMENTS		
 Multi Transducers		

ULTRASONIC MEASUREMENT		
 Back-up Data		

CONTENTS

About Norbar	2
Introduction to Torque	3
ISO 6789:2017	9
Torque Screwdrivers	11
TT Torque Wrenches	11
TTi Non-Magnetic Torque Wrenches	12
NorTorque® Torque Wrenches	13
Slimline™ Torque Wrenches	15
Professional Torque Wrenches Model 5	16
Professional Torque Wrenches	17
Professional 'P' Type Torque Wrenches	21
Professional Torque Wrenches Models 650 - 1500	23
Industrial Torque Wrenches	25
Electrode Torque Wrenches	27
Insulated Torque Wrenches	28
NorTorque® Tethered Torque Wrenches	28
ClickTronic® Torque Wrenches	29
NorTronic® Torque Wrenches	31
Spanner End Fittings	33
UKAS Accredited Calibration Certification	37
HandTorque® Torque Multipliers	38
Powered Torque Tools	50
Lubro Control Units	77
Torque Measurement	78
Transducers	89
Loaders & Attachments	98
Test Rigs and Fixtures	103
Hydraulic Tool Calibration Fixtures	106
Tool Controllers	110
Harsh Environment (HE) Range	112
Engineer To Order (ETO)	117
Ultrasonic Measurement	118
Calibration Beams & Weights	120
Spares Kits	125
Service Replacement Policy	125
Calibration Services	129
General Notes	134
Terms & Conditions	135





ABOUT NORBAR - THE VOICE OF TORQUE CONTROL



GLOBAL SERVICE

We are the world's leading specialist in torque control and we are engaged solely in the design, development and production of torque tightening and measuring equipment.

Our customers include manufacturers and engineering services in such diverse sectors as aerospace, energy, oil and gas, mining and sub-sea.

There are sales and service branches in Australia, New Zealand, North America, Singapore, China and India. In addition, we have distributors of our torque control products in more than 60 countries around the world.

A FAMILY BUSINESS

The Brodey family has been a part of Norbar since Bill Brodey and his partner Ernest Thornitt incorporated the company in 1943. We are now the third generation of the family to participate in the business and are passionate about its every aspect. From our humble beginnings in a small workshop in North Bar, Banbury town centre, Norbar has grown into an international group of companies that leads the field of torque control. However, what has not changed in over 75 years is that our product range is still substantially manufactured in Banbury with many suppliers in the surrounding area and we are still dedicated to being the best at what we do. As Bill Brodey's original slogan stated made in Banbury in accordance with time-honoured tradition.

In our 2020 catalogue you will find the latest on our range of EvoTorque® Battery Tools (EBT) that have been taking the market by storm since their launch in October 2019. We are also presenting the new range of TruCheck™ 2 torque checkers which bring exciting new features such as full colour display and USB data output to the Norbar introductory range of torque checkers. At the other end of the torque measurement range, the magnificent new T-Box™ 2 brings a 10 inch HD colour display and, for the first time from Norbar, the ability to run two transducers simultaneously. There are new models of our re-engineered Industrial "break-back" torque wrenches and a new section on power tools for hard to access applications, taking Norbar pneumatic and electric power tools to previously inaccessible bolts.

We continue to invest in the very latest design, manufacturing and quality control technology to achieve the highest level of innovation and precision in the field of torque control and equipment.





INTRODUCTION TO TORQUE

What is Torque?

Torque is any force or system of forces that tends to cause rotation about an axis.

Measurement of Torque

Imagine someone tightening a bolt using a socket attached to a meter (m) long bar. If they apply 10 kg of force (kgf) perpendicular to the bar they will produce a torque of 10 kgf·m at the axis (the centre of the bolt).

However, under the S.I. system of measurement, force is expressed in Newtons (N) rather than kgf. The conversion between kgf and N is x 9.807 so the person is applying 98.07 N·m of torque.

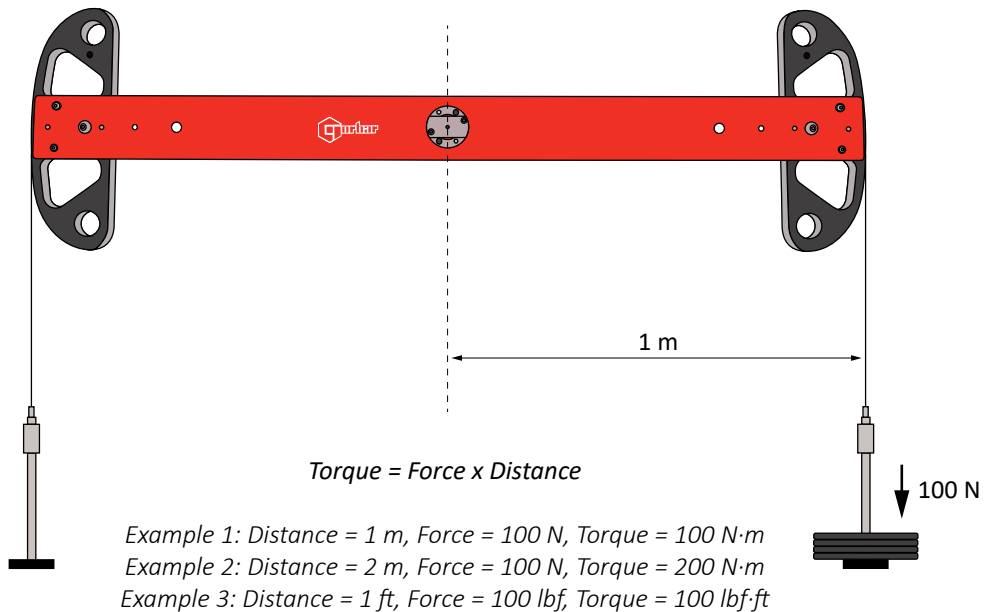

The Importance of Torque Control

Although many methods exist to join two or more parts together, the ease of assembly and disassembly provided by threaded fasteners make them the ideal choice for many applications.

The object of a threaded fastener is to clamp parts together with a tension greater than the external forces tending to separate them. The bolt then remains under constant stress and is immune from fatigue. However, if the initial tension is too low, varying loads act on the bolt and it will quickly fail. If the initial tension is too high, the tightening process may cause bolt failure. Reliability therefore depends upon correct initial tension. The most practical way of ensuring this is by specifying and controlling the tightening torque.

Bolt Tension

When an assembly is clamped by tightening a nut and bolt, the induced tension causes the bolt to stretch. An equal force acts to compress the parts which are thus clamped.

The proof load of a bolt, normally established by test, is the load which just starts to induce permanent set – also known as the yield point. Typically bolts are tightened to between 75% and 90% of yield.

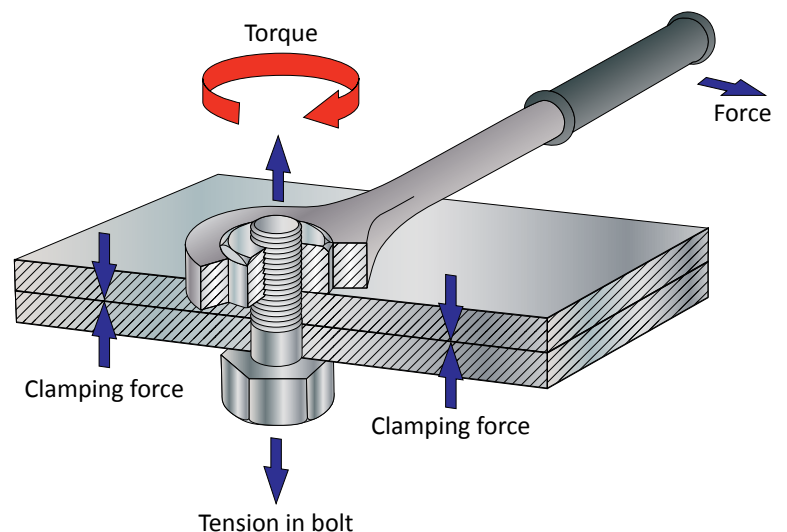



INTRODUCTION TO TORQUE

Friction in the Bolted Joint

When a threaded fastener is tightened, the induced tension results in friction under the head of the bolt and in the threads. It is generally accepted that as much as 50% of the applied torque is expended in overcoming friction between the bolt head and the abutting surface and another 30% to 40% is lost to friction in the threads. As little as 10% of the applied torque results in useful work to tension the bolt.

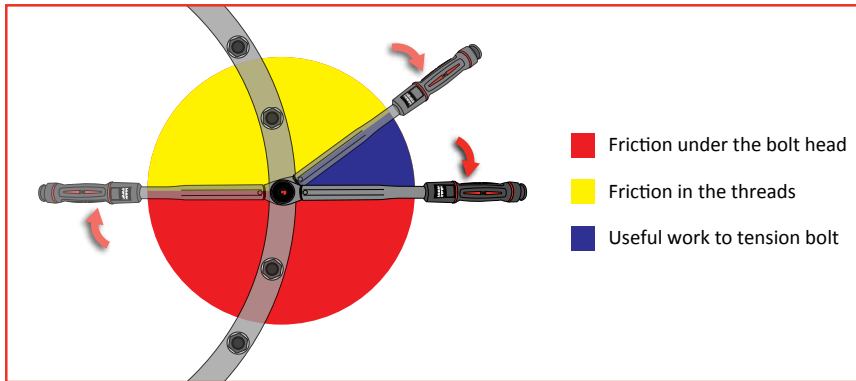

Given that up to 90% of the applied torque will be lost to friction, it follows that any changes in the coefficient of friction resulting from differences in surface finish, surface condition and lubrication can have a dramatic effect on the torque versus tension relationship. Some general points can be made:

- Most torque tightened joints do not use washers because their use can result in relative motion between the nut and washer or the washer and joint surface during tightening. This has the effect of changing the friction radius and hence affects the torque-tension relationship. Where a larger bearing face is required then flange nuts or bolts can be used. If washers are to be used, hard washers with a good fit to the shank of the bolt give lower and more consistent friction and are generally to be preferred.
- Degreasing fasteners of the film of oil usually present on them as supplied will decrease the tension for a given torque and may result in shear of the fastener before the desired tension is achieved.
- Super lubricants formulated from graphite, molybdenum disulphide and waxes result in minimal friction. Unless allowance is made in the specified tightening torque, the induced tension may be excessive causing the bolt to yield and fail. However, used in a controlled manner, these lubricants serve a useful purpose in reducing the torque to produce the desired tension meaning that a lower capacity tightening tool can be used.
- For reasons of appearance or corrosion resistance, fasteners may be plated. These treatments affect the coefficient of friction and therefore the torque versus tension relationship.
- Friction is often deliberately introduced into the fastener to reduce the possibility of loosening due to vibration. Devices such as lock-nuts must be taken into account when establishing the correct tightening torque.

As a rough guide, the calculated tightening torque should be multiplied by the factor from the table below according to surface treatment and lubrication.

		Surface Condition of Bolt			
		Untreated	Zinc	Cadmium	Phosphate
Surface Condition of Nut	Untreated	1.00	1.00	0.80	0.90
	Zinc	1.15	1.20	1.35	1.15
	Cadmium	0.85	0.90	1.20	1.00
	Phosphate and oil	0.70	0.65	0.70	0.75
	Zinc with wax	0.60	0.55	0.65	0.55



INTRODUCTION TO TORQUE

Tightening to Yield

Bolts tightened to yield provide consistently higher preloads from smaller diameter bolts. The reduced fastener stiffness reduces the fatigue loading to which the bolt is subjected under repeated external load reversals, e.g. cylinder heads and connecting rods.

In theory, a bolt tightened to its yield point will provide the strongest and most fatigue-resistant joint possible, within the physical limitations of the bolt material and manufacturing process.

The downside of this method is the cost of the sophisticated equipment necessary to determine when the bolt goes into yield.

Torque Tension Calculator

For further information and guidance on establishing the correct tightening torque for a fastener, see Norbar’s web based calculator, www.norbar.com/Home/Torque-Tension-Calculator



Calculated Maximum Torque
N.m.: 0.05
lbf. ft.: 0.04

Calculated Maximum Load
kN: 0.15
lbf: 34.7

Bolt Properties

Bolt Diameter	1.6 mm
Yield Stress	180 Nmm ²
Pitch	0.35 mm
Pitch Diameter	1.373 mm
Root Diameter	1.171 mm
Hex A/F Diameter	3.2 mm

Standard Parameters

Bolt Type: Metric Coarse
Bolt Dia.: 1.6
Grade: 3.6

Friction Coefficients

Thread: 0.14
Head: 0.14

These torque and load values are for guidance only! Always check with equipment/bolt manufacturer

When Torque Doesn't Equal Tight

As we have established, it is the tension in a fastener rather than the torque that is the critical factor. Torque is an indirect means of establishing tension and in a correctly engineered joint and with a controlled tightening process, it is a satisfactory method under the majority of circumstances.

However, in joints that are highly critical due to safety or the cost and implications of machine down-time, a more direct means of establishing tension is needed. Various methods exist including several types of load indicating bolts or washers. However, one of the most versatile methods is to measure the extension of the bolt due to the tightening process using ultrasound.

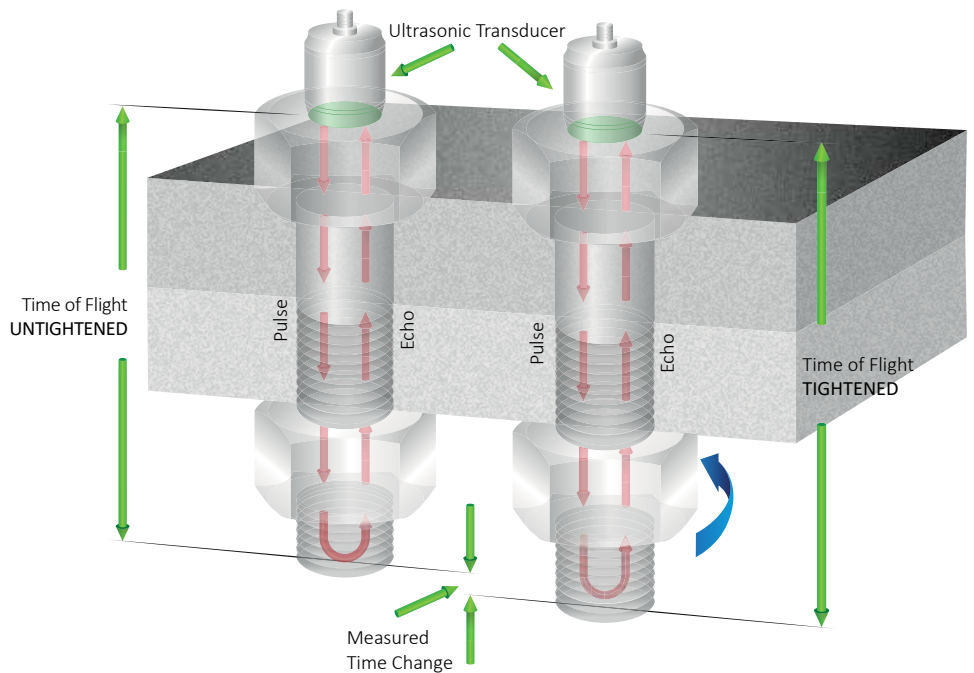





INTRODUCTION TO TORQUE

Recommended Maximum Torque Values

The information supplied here is intended to be an acceptable guide for normal conditions. For critical applications, further information and research will be necessary. The following basic assumptions have been made:

- a. Bolts are new, standard finish, uncoated and not lubricated (other than the normal protective oil film)
- b. The load will be 90% of the bolt yield strength
- c. The coefficient of friction is 0.14
- d. The final tightening sequence is achieved smoothly and slowly

If lubrication is to be applied to the nut/bolt, multiply the recommended torque by the appropriate factor shown in the table on page 4. Alternatively, use the Torque/Tension Calculator on the Norbar website (shown on page 5) which enables fastener and friction conditions to be modified with ease.

 M	BOLT GRADE									 mm
	3.6	4.6	5.6	5.8	6.8	8.8	9.8	10.9	12.9	
	Torque in N·m									
M 1.6	0.05	0.07	0.09	0.11	0.14	0.18	0.21	0.26	0.31	3.2
M 2	0.11	0.14	0.18	0.24	0.28	0.38	0.42	0.53	0.63	4
M 2.5	0.22	0.29	0.36	0.48	0.58	0.78	0.87	1.09	1.31	5
M 3	0.38	0.51	0.63	0.84	1.01	1.35	1.52	1.9	2.27	5.5
M 4	0.71	0.95	1.19	1.59	1.91	2.54	2.86	3.57	4.29	7
M 5	1.71	2.28	2.85	3.8	4.56	6.09	6.85	8.56	10.3	8
M 6	2.94	3.92	4.91	6.54	7.85	10.5	11.8	14.7	17.7	10
M 8	7.11	9.48	11.9	15.8	19	25.3	28.4	35.5	42.7	13
M 10	14.3	19.1	23.8	31.8	38.1	50.8	57.2	71.5	85.8	17
M 12	24.4	32.6	40.7	54.3	65.1	86.9	97.9	122	147	19
M 14	39	52	65	86.6	104	139	156	195	234	22
M 16	59.9	79.9	99.8	133	160	213	240	299	359	24
M 18	82.5	110	138	183	220	293	330	413	495	27
M 20	117	156	195	260	312	416	468	585	702	30
M 22	158	211	264	352	422	563	634	792	950	32
M 24	202	270	337	449	539	719	809	1,011	1,213	36
M 27	298	398	497	663	795	1,060	1,193	1,491	1,789	41
M 30	405	540	675	900	1,080	1,440	1,620	2,025	2,430	46
M 33	550	734	917	1,223	1,467	1,956	2,201	2,751	3,301	50
M 36	708	944	1,180	1,573	1,888	2,517	2,832	3,540	4,248	55
M 39	919	1,226	1,532	2,043	2,452	3,269	3,678	4,597	5,517	60
M 42	1,139	1,518	1,898	2,530	3,036	4,049	4,555	5,693	6,832	65
M 45	1,425	1,900	2,375	3,167	3,800	5,067	5,701	7,126	8,551	70
M 48	1,716	2,288	2,860	3,813	4,576	6,101	6,864	8,580	10,296	75
M 52	2,210	2,947	3,684	4,912	5,895	7,859	8,842	11,052	13,263	80
M 56	2,737	3,650	4,562	6,083	7,300	9,733	10,950	13,687	16,425	85
M 60	3,404	4,538	5,673	7,564	9,076	12,102	13,614	17,018	20,422	90
M 64	4,100	5,466	6,833	9,110	10,932	14,576	16,398	20,498	24,597	95
M 68	4,963	6,617	8,271	11,029	13,234	17,646	19,851	24,814	29,777	100



INTRODUCTION TO TORQUE

Torque Conversion Factors

Units to be converted	S.I. Units		Imperial Units			Metric Units	
	cN·m	N·m	ozf·in	lbf·in	lbf·ft	kgf·cm	kgf·m
1 cN·m =	1	0.01	1.416	0.088	0.007	0.102	0.001
1 N·m =	100	1	141.6	8.851	0.738	10.20	0.102
1 ozf·in =	0.706	0.007	1	0.0625	0.005	0.072	0.0007
1 lbf·in =	11.3	0.113	16	1	0.083	1.152	0.0115
1 lbf·ft =	135.6	1.356	192	12	1	13.83	0.138
1 kgf·cm =	9.807	0.098	13.89	0.868	0.072	1	0.01
1 kgf·m =	980.7	9.807	1389	86.8	7.233	100	1

FORCE

$$\text{lbf} \times 4.45 = \text{N}$$

$$\text{N} \times 0.225 = \text{lbf}$$

FLOW

$$\text{l/s} \times 2.119 = \text{cu-ft/min}$$

$$\text{cu-ft/min} \times 0.472 = \text{l/s}$$

PRESSURE

$$\text{lbf/in}^2 \times 0.069 = \text{bar}$$

$$\text{bar} \times 14.504 = \text{lbf/in}^2$$

POWER

$$\text{hp} \times 0.746 = \text{kW}$$

$$\text{kW} = \frac{\text{N}\cdot\text{m} \times \text{rev/min}}{9,546}$$

Formulae

Accepted formulae relating torque and tension, based on many tests are:-

For Imperial Sizes

$$M = \frac{P \times D}{60}$$

M = torque lbf·ft
P = bolt tension lbf
D = bolt diameter (ins)

For Metric Sizes

$$M = \frac{P \times D}{5000}$$

M = torque N·m
P = bolt tension Newtons
D = bolt diameter (mm)

These formulae may be used for bolts outside the range of the tables.

Formula for Calculating the Effect of Torque Wrench Extensions

$$M1 = M2 \times L1/L2$$

Where L1 is the normal length and L2 is the extended length, M1 is the set torque and M2 the actual torque applied to the nut.

Example

The required torque on the fastener is 130 N·m (M2) but what do you set on the torque wrench scale?

$$L1 = 500 \quad L2 = 650$$

(units of length not important, this is ratio)

$$M1 = 130 \times 500/650$$

$$M1 = 100$$

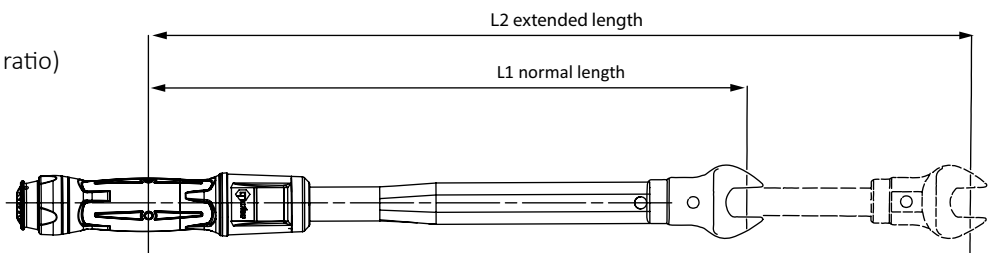

For further information and guidance on converting torque and calculating the effect of torque wrench extensions download our purpose-built applications for iPhone and Android.



TORQUE MEASUREMENT

Norbar started manufacturing electronic torque measuring instruments in the early 1970s and now offers a comprehensive range, from the easy to use, cost effective TruCheck™ 2 through to the sophisticated T-Box™ 2. Norbar's torque measuring instruments are renowned for high accuracy and superb reliability. Indeed, many of those early instruments are still in regular use today. For our interchangeable transducer instruments, we remain one of the few manufacturers in the world that issue a UKAS accredited calibration certificate both for the instrument and for the torque transducer. In doing so, customers can swap combinations of instrument and transducer while retaining complete traceability.

Norbar's torque transducers have established an excellent reputation based on exceptional quality and accuracy. A very wide torque range is covered, 0.04 to 300,000 N·m and three basic transducer configurations are offered; Static, Impulse Rotary and Annular.

All transducers up to 100,000 N·m are supplied as standard with a UKAS accredited calibration certificate from Norbar's in-house laboratory.

For customers who wish to take advantage of Norbar's transducers but have an existing, non-Norbar display instrument, transducers can be provided with a mV/V calibration.

Norbar's instruments and transducers are complemented by a wide range of ancillary products. Within this group are the products that would be required to set up a torque calibration laboratory, for example, torque wrench calibrators meeting ISO requirements and precision beam and weight systems for calibration of torque transducers.

Torque Measurement	79
TruCheck™ 2	80
T-Box™ 2	83
Torque Screwdriver Tester (TST)	85
Torque Tool Tester (TTT)	86
Pro-Test	87
Spares for Instrumentation Products	88
Part Number Suffix System	88
Static Transducer Bench Stands	88
Static Transducers	89
Flange Mounted Transducers (FMT)	92
Rotary Transducers	93
Annular Transducers	94
Transducer Leads	98
ISO 3000 Loader	98
Torque Wrench Calibrator - Manual	99
Torque Wrench Calibrator - Ancillaries	100
Torque Wrench Calibrator - Auto	101
Test Rigs and Fixtures	103





Measurement and Calibration - Glossary of Terms

The following information may help in selecting the appropriate measuring device for your needs.

Accuracy

The precision of the instrument which can be reported in three ways:

1. By quoting the guaranteed tolerance as a percentage of the reading or indicated value (eg. '0.5% of reading').
2. By quoting the guaranteed tolerance as a percentage of the full scale value of the instrument (eg. 0.1% FS or 0.1% FSD).
3. By quoting a 'class' of device in accordance with BS7882:2017 'Method for calibration and classification of torque measuring devices'.

Modes of Operation

First Peak of Torque - when a 'click type' torque wrench signals that the set torque has been achieved, the applied torque will momentarily drop before climbing again. Generally the fastener stops rotating at point 1 and from a standstill, the breakaway torque to achieve further rotation of the fastener will be higher than point 3b. Only if the operator is very insensitive to the break point will the final tightening effort be incorrect.

'First Peak of Torque' mode will detect the break point of the torque wrench, not the highest torque applied.

Peak Torque - this mode of operation will record the highest torque applied. In the case of a 'click type' torque wrench this may be higher than the actual break point if the wrench continues to be loaded beyond the break.

Consequently, Peak Torque is more useful for calibrating devices without a break signal such as dial or electronic wrenches.

Track - this mode has no memory at all. When the load is removed the display will return to zero.

Track is used for calibrating the device itself or for monitoring a fluctuating torque.

Resolution

The smallest measurement interval that can be determined on the indicating device. This applies to analogue and digital devices.

Number of Digits

Digital displays are described as having a certain number of 'digits' or 'active digits'. Half digits can be used to increase the resolution of a device without the expense of going to an additional full active digit.

Example 1. 1,000 N·m displayed on a 4 digit system would read 1000 (resolution = 1 N·m).

Example 2. 1,000 N·m displayed on a 4½ digit system would read 1000.0 (resolution = 0.1 N·m).

Active digits change as the torque changes. Non-active digits only assist in showing the magnitude of the torque. For example, 10,000 N·m requires 5 digits to display its magnitude.

Example 3. With 4 active digits (and 1 passive digit), 10,000 N·m would change in steps of 10 N·m.

Example 4. With 4½ or 5 active digits, 10,000 N·m would change in steps of 1 N·m.

Signal Processing

Electronic circuitry falls broadly into two types, analogue and digital, with most electronic measurement systems comprising a mixture of the two. There are also whole analogue electronic systems, but these are rare in torque measurement. Most systems start with an analogue signal. The point at which the signal is converted defines the type.

Analogue systems – one in which the signal is processed before being converted to digital.

Digital systems – the original analogue signal is converted to digital before processing.

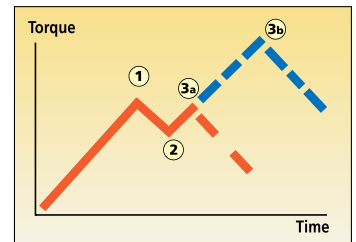

- 1 = Torque wrench activates
- 2 = 'Click' heard
- 3a = Wrench released quickly
- 3b = Wrench released slowly



TRUCHECK™ 2



This cost-effective torque wrench checker has been redesigned to incorporate improved features whilst maintaining ease of use. The TruCheck™ 2 aims to cut the cost of purchasing a torque wrench checking system and remove the fears over the complexity of using such equipment.

- Enables torque wrench performance to be monitored as part of your strategy to keep wrenches in peak condition
- LCD display with clear target indication from colour changing display (Plus version only). Visible in poorly lit work areas.
- Two versions, TruCheck™ 2 and TruCheck™ 2 Plus available
- 'Basic' version has limited settable options. Ideal for non-expert users with click type torque wrenches
- TruCheck™ 2 Plus allows a selection of torque units, three modes of operation (Click, Dial and Track), the ability to store up to 15 targets and select from 12 languages
- Plus version allows operator to set a target value and tolerance
- ±1% of reading accuracy (±2% when below 10% of range for the 10 N·m and 1,100 N·m TruCheck™ 2 model)
- Inbuilt Micro USB 2.0 port enables power from any USB power source. Plus version allows for both power and data transfer simultaneously
- Supplied with traceable calibration certificate



TruCheck™ 2 Plus display showing above target tolerance



TruCheck™ 2 Plus display showing within target tolerance



TruCheck™ 2 Plus display showing below target tolerance

NOTE: Some TruCheck™ 2 models are currently in development and are subject to change, therefore the information provided may alter upon the launch of these models.



TRUCHECK™ 2 (0.1 - 30 N·m)



TruCheck™ 2 Plus 3 N·m



TruCheck™ 2 with Torque Screwdriver (not included)

4	TRUCHECK 2 (0.1 - 30 N·m)
43514*	TruCheck 2, 0.1 - 3 N·m
43515*	TruCheck 2 Plus, 0.1 - 3 N·m
43516*	TruCheck 2, 0.5 - 10 N·m
43517*	TruCheck 2 Plus, 0.5 - 10 N·m
43518*	TruCheck 2, 1.5 - 30 N·m
43519*	TruCheck 2 Plus, 1.5 - 30 N·m
TCACC.CW	UKAS accredited calibration - clockwise
TCACC. CW+CCW	UKAS accredited calibration - clockwise and counter-clockwise

* 43514, 43515, 43516 and 43517 supplied with 1/4" male hexagon and 1/4" female sq. dr. adapter

* 43518 and 43519 supplied with 10 mm male hexagon, 1/4" and 3/8" female sq. dr. adapter

NOTE: If you order a UKAS accredited calibration, this certificate will be provided in place of the traceable calibration certificate and over the operating range as indicated on the device.

Model	TruCheck 2/Plus 0.1 - 3.0 N·m 0.5 - 10 N·m	TruCheck 2/Plus 1.5 - 30 N·m	
Part Number	43514, 43515, 43516, 43517	43518, 43519	
Range	0.1 - 3.0 N·m 0.5 - 10 N·m	1.5 - 30 N·m	
In-Built Transducer Male Hex Drive Size	1/4"	10 mm	
Dimensions (mm)	A	175	175
	B	10	10
	ØC	6.5	6.5
	D	55	55
	E	10	10
	F	64	64
	G	N/A	72
	H	64	64
J	72	N/A	
Weight (kg)	1.4	1.4	

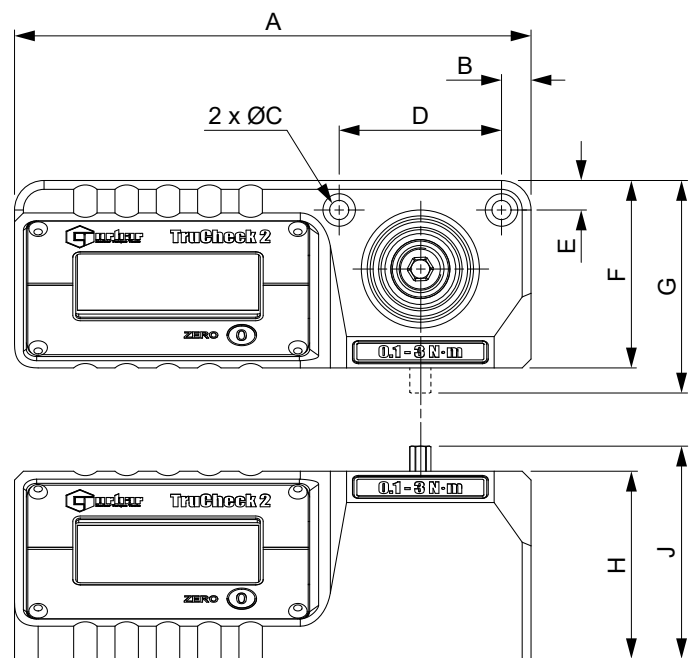

NOTE: The male hexagon on the 3 N·m and 10 N·m models is vertically aligned. The 30 N·m model male hexagon is horizontally aligned.



TRUCHECK™ 2 (3 - 2,100 N·m)



4	TRUCHECK 2 (3 - 2,100 N·m)
43520*	TruCheck 2, 3 - 65 N·m
43521*	TruCheck 2 Plus, 3 - 65 N·m
43522+	TruCheck 2, 10 - 260 lbf·ft
43523+	TruCheck 2 Plus, 10 - 260 lbf·ft
43524+	TruCheck 2, 10 - 350 N·m
43525+	TruCheck 2 Plus, 10 - 350 N·m
43528®	TruCheck 2, 40 - 800 lbf·ft
43529®	TruCheck 2 Plus, 40 - 800 lbf·ft
43530®	TruCheck 2, 50 - 1,100 N·m
43531®	TruCheck 2 Plus, 50 - 1,100 N·m
43532^	TruCheck 2, 200 - 2,100 N·m
43533^	TruCheck 2 Plus, 200 - 2,100 N·m
TCACC.CW	UKAS accredited calibration - clockwise
TCACC. CW+CCW	UKAS accredited calibration - clockwise and counter-clockwise

- * 43520 and 43521 supplied with 3/8" female square drive
- + 43522, 43523, 43524 and 43525 supplied with 1/2" female square drive
- ® 43528, 43529, 43530 and 43531 supplied with 27 mm male hexagon plus 3/4" female sq. dr. adapter
- ^ 43532 and 43533 supplied with 27 mm male hexagon plus 1" female sq. dr. adapter

NOTE: If you order a UKAS accredited calibration, this certificate will be provided in place of the traceable calibration certificate and over the operating range as indicated on the device.

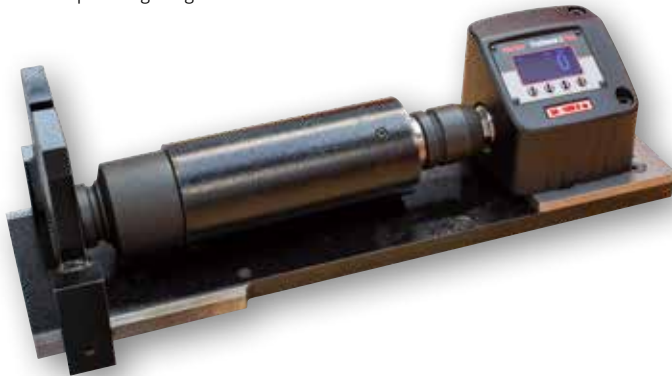

TruCheck™ 2 Plus 1100 shown with a Power Tool Test Fixture (not included - see page 103) allowing for cost-effective checking of power tools

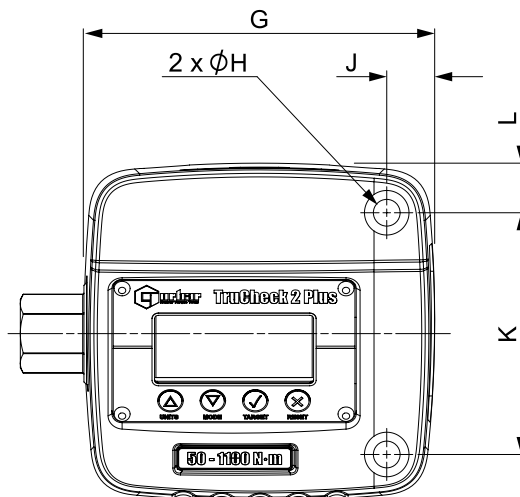
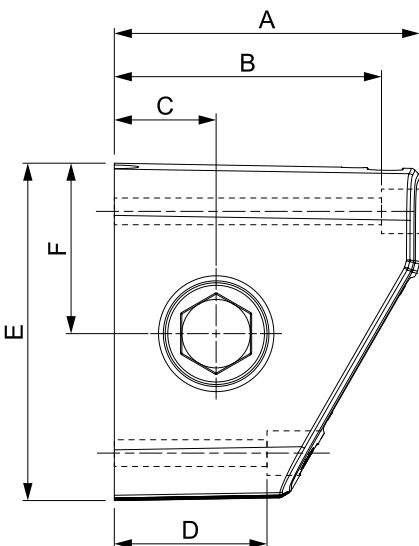

TruCheck™ 2 Plus
1,100 N·m



TruCheck™ 2 Plus
350 N·m

Model	TruCheck 2/Plus 3 - 65 N·m 10 - 260 lbf·ft 10 - 350 N·m	TruCheck 2/Plus 40 - 800 lbf·ft 50 - 1,100 N·m 200 - 2,100 N·m
Part Number	43520, 43521, 43522, 43523, 43524, 43525	43528, 43529, 43530, 43531, 43532, 43533
Dimensions (mm)	A	110
	B	95
	C	40
	D	50
	E	117
	F	59
	G	138
	ØH	10.5
	J	19
	K	80
L	19	
Weight (kg)	2.6	3.5



T-BOX™ 2



New



The T-Box™ 2 utilises its powerful processor to provide a seamless and complete torque data collection package. This is capable of tool calibrations, data logging, simultaneous transducer connections and archiving to your PC.

- Accuracy of $\pm 0.05\%$ of reading ($\pm 0.1\%$ when below 5% of transducer capacity)
- Features a 10.1" multi-touch screen display with on-screen graphic icons for simple and easy tool navigation and selection
- Features Gorilla® Glass with native damage resistance helping to prevent deep chips and scratches appearing on the screens surface
- 2 transducer ports gives you the ability to perform 2 tasks simultaneously e.g. graphing & measuring
- Two task windows allows simultaneous working! Measure against a target while graphing the cycle, take readings from two transducers simultaneously, capture two different graphs at the same time or manage and review readings as they are captured
- The T-Box™ 2 can capture graphs up to 325 Hz, offering the ability to analyse fast moving transients
- User configurable to allow a selection of torque, torque and angle, rate targets and the ability to set thresholds
- Ability to predefine multiple targets
- 2 USB ports, 1 RS-232 serial port and 2 independantly configurable ancillary ports
- Includes 6 modes for torque tool measurement: Track, Click, Dial & Electronic, Stall, Screwdriver and Hydraulic
- File browser/manager for internal storage and USB management giving the user greater ease and flexibility in managing multiple files and folders
- Can export readings and graphs to CSV and JSON format allowing for 3rd party software integration
- Ability to network via USB adapter
- Continuous output of up to 100 readings per second via RS-232 or USB virtual serial devices
- Fast CPU frequency up to 2.3 GHz
- Large capacity memory of 120GB SSD storage
- 4GB RAM allows for smooth and seamless operation
- Bench stand supplied as standard with an adjustable viewing angle
- Rear panel features 100 mm x 100 mm VESA mounting holes, allowing for easy wall mounting or the use of third party stands / arms
- Fully supports the use of a keyboard and mouse (not supplied)
- The Analogue Board Module (not supplied) offers the convenience to plug in more than 2 transducers into the T-Box™ 2. Also offers the advantage of being able to place your transducer at a distance to your T-Box™ 2 with no detrimental effects on the measurement signal.



61908 TDMS USB Flash Drive



AnB Module

4	T-BOX 2
43542	T-Box 2 Instrument with TDMS Software

4	TDMS SOFTWARE
61908	TDMS Software (supplied on USB Flash Drive) Supplied as standard with T-Box™ 2.

4	ANALOG BOARD (AnB) MODULE
43543	Single Port AnB Module via USB



T-BOX™ 2



Displaying 2 transducer readings simultaneously



Storage destination (left) file browser (right)



Home menu for 2 separate windows

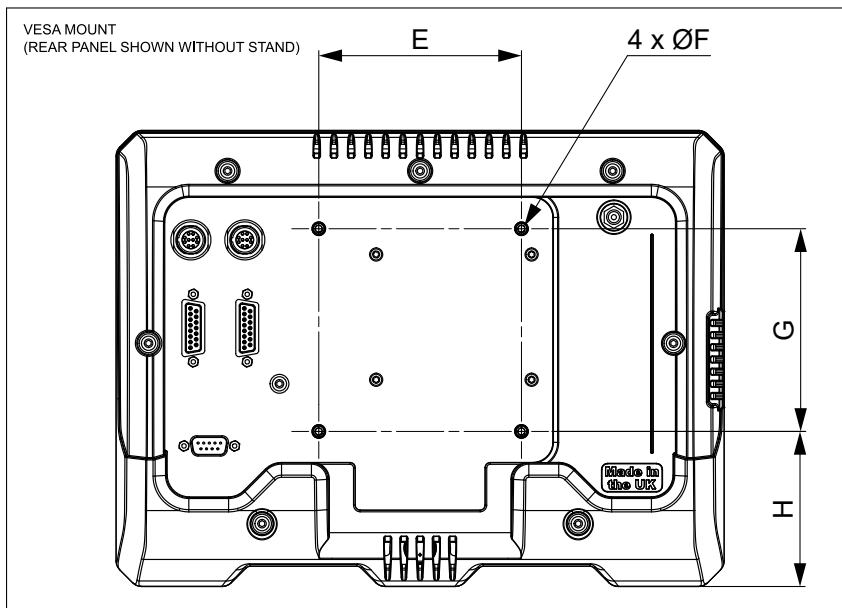
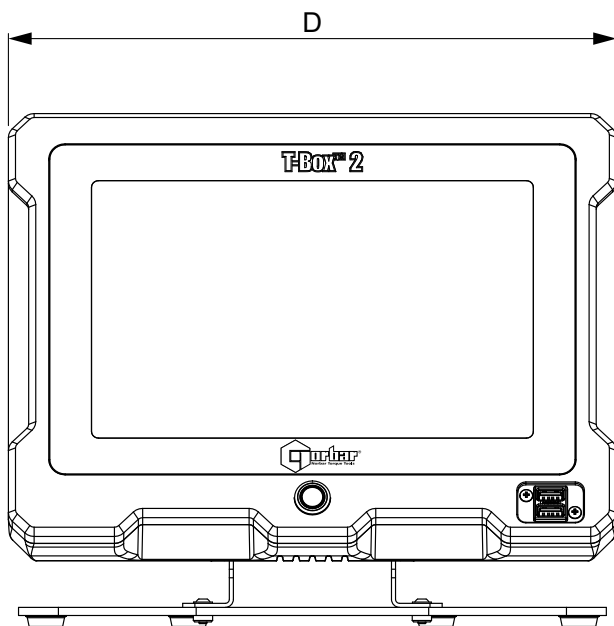
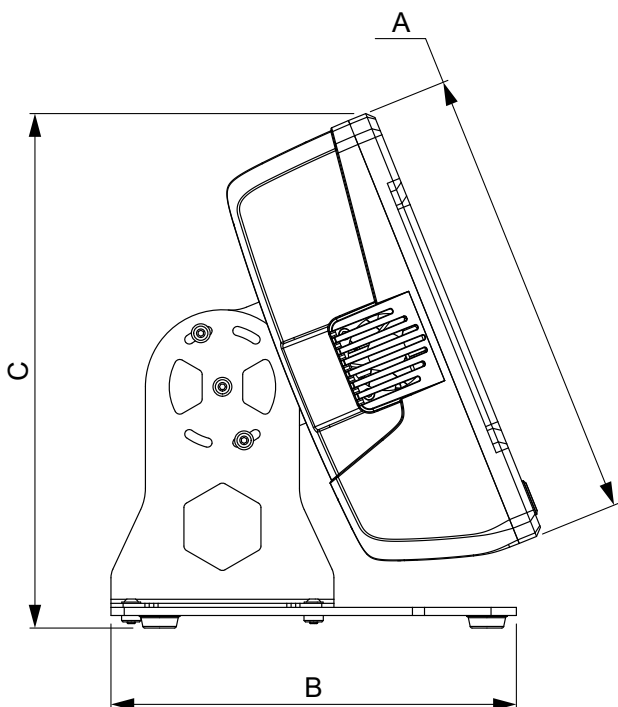

Model	T-Box 2	
Part Number	43542	
Dimensions (mm)	A	225
	B	200
	C	254
	D	300
	E	100
	ØF	M4
	G	100
Weight (kg)	5.2	

T-Box™ 2 back panel allows for 2 transducers to connect simultaneously, 1 RS-232 serial port and 2 ancillary ports

NOTE: T-Box™ 2 is currently in development and is subject to change, therefore the information provided may alter upon the launch of the product.



TORQUE SCREWDRIVER TESTER (TST)



The Torque Screwdriver Tester (TST) combines simplicity and functionality to provide a high quality instrument for the testing and calibration of low capacity torque tools.

Featuring an internal transducer complete with Rundown Fixture, the TST is available in 3 torque ranges, 0.04 to 2 N·m, 0.5 to 10 N·m and 1.25 to 25 N·m. Class 1 system accuracy over its Primary range ($\pm 0.5\%$ of reading from 20% to 100% of full scale).

What makes the TST genuinely versatile is the interface for an external transducer. This interface, accessed by a 2 way switch on the TST, allows the connection of any transducer from Norbar's Smart range and most mV/V calibrated transducers from Norbar or other manufacturers.

- Pictorial display panel for easy mode selection
- Limit detection with low, pass and fail indication. Up to 8 target values can be set
- Digital limit state output for control of external tools
- Operation from fast charge internal battery pack (maximum time of 3 hours 20 minutes for full charge) or a.c. supply (90 to 264 Volts)
- RS-232-C serial data interface for connection to a printer or PC. Continuous RS-232 output when used in Track mode (up to 11 readings per second)
- Pulse count feature in Impulse mode and Clutch Tool mode
- Smart intelligence for transducer recognition
- Memory for calibration details of 20 non-Smart mV/V calibrated transducers
- Analogue output allows the instrument to be used as part of a process control system for performance analysis
- User-selectable frequency response for each mode of operation
- All user-selectable features have password protection. The instrument can be issued to users with only the required modes of operation and units of measure enabled. This feature can virtually eliminate operator induced errors
- ¼" female hex to ¼" female square adaptor comes supplied as standard



4	TST SERIES 2
43212	TST 2, 0.04 - 2 N·m
43213	TST 10, 0.5 - 10 N·m
43214	TST 25, 1.25 - 25 N·m
TST.CCW	Counter-clockwise calibration when ordered with new unit

Above part numbers exclude Transducer lead for external transducer (see page 98).

TST is supplied complete with a Rundown Fixture for joint simulation. Additional rundowns are available see page 92.



Model	All Models
Part Number	43212 43213 43214
Dimensions (mm)	A 290
	ØB 10
	C 40
	D 32
	E 123
	F 160
	G 61
	H 149
Weight (kg)	4.7

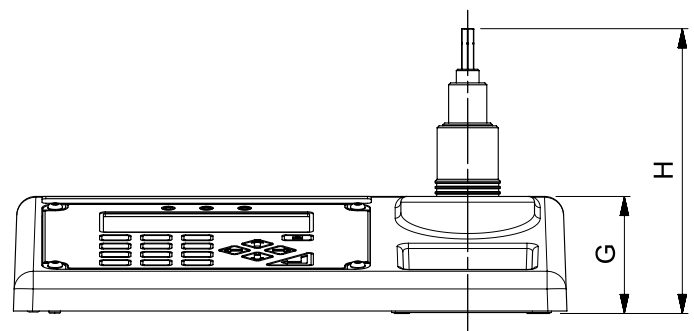
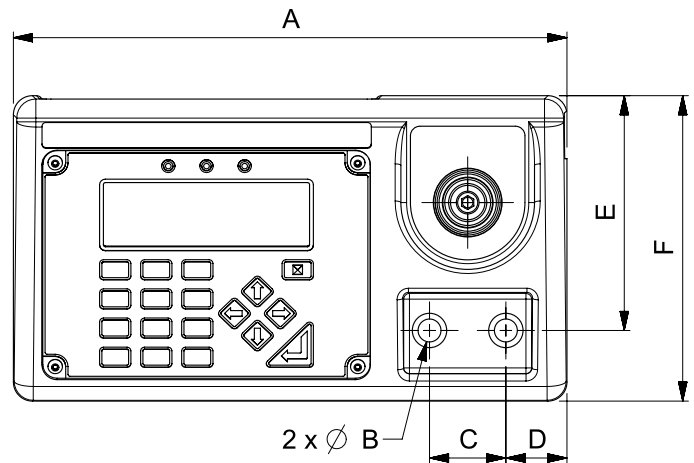



TORQUE TOOL TESTER (TTT)



The Torque Tool Tester (TTT) shares all of the extensive features of the Torque Screwdriver Tester (TST) except that it has no internal transducer. Instead, the TTT offers not one but three external transducer interfaces allowing any three transducers to be simultaneously connected. Selection between the transducers is made by a rotary switch at the back of the instrument case.

Any transducer from Norbar’s Smart range and most mV/V calibrated transducers from Norbar or other manufacturers can be connected to the TTT. The Smart feature means that once a transducer has been connected, the instrument will automatically recognise calibration details such as mV/V output, serial number and capacity.

- Pictorial display panel for easy mode selection
- Limit detection with low, pass and fail indication. Up to 12 target values can be set
- Digital limit state output for control of external tools
- Operation from fast charge internal battery pack (maximum time of 3 hours 20 minutes for full charge) or a.c. supply (90 to 264 Volts)
- RS-232-C serial data interface for connection to a printer or PC. Continuous RS-232 output when used in Track mode (up to 11 readings per second)
- Pulse count feature in Impulse mode and Clutch Tool mode
- Smart intelligence for transducer recognition, now displays transducer capacity, units and Serial Number
- Memory for calibration details of 20 non-Smart mV/V calibrated transducers
- Analogue output allows the instrument to be used as part of a process control system for performance analysis
- User-selectable frequency response for each mode of operation
- All user-selectable features have password protection. The instrument can be issued to users with only the required modes of operation and units of measure enabled. This feature can virtually eliminate operator induced errors
- Peak memory modes can now be configured to have auto reset (previously only manual reset was possible)
- Series 3 users can set up their own measurement units, making it possible to interface with non-torque transducers, for example load or pressure



4	TTT SERIES 3
43228	TTT Instrument
TTT.CCW	Counter-clockwise calibration when ordered with new unit
Above TTT part number excludes Transducer leads (see page 98)	



Model	All Models	
Part Number	43228	
Dimensions (mm)	A	152
	B	181
	C	200
Weight (kg)	4.8	

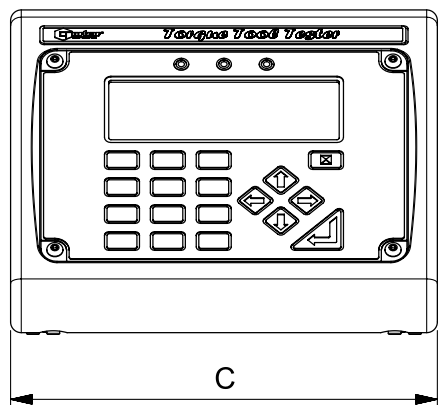
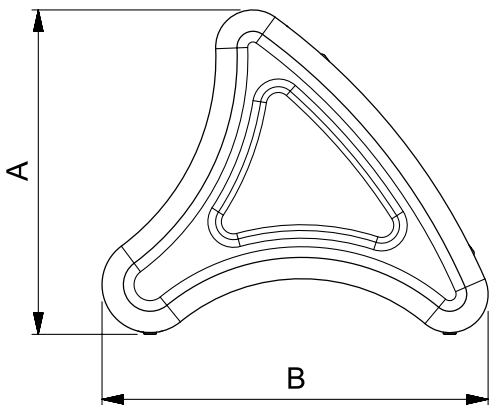



PROFESSIONAL TORQUE TESTER (PRO-TEST)



The Professional Torque Tester (Pro-Test) - Series 2, is an accurate, highly specified and easy to operate instrument for testing and calibrating all types of torque wrench.

- Pro-Test is priced to make in-house testing a viable proposition even for the smaller industrial and automotive torque wrench user
- Guaranteed classification to BS7882:2017, Class 1 or better over the primary calibration range (20% to 100% of full scale), Class 2 or better over the secondary calibration range (lowest calibrated value to 20% of full scale). Class 1 equates to $\pm 0.5\%$ of reading
- Three essential operating modes allow the Pro-Test to be used with all torque wrench types 'Track' displays the live value, 'Peak Memory' records the highest value and 'First Peak Memory' records the first peak of torque (for click type torque wrenches). Both memory modes can be used with manual or automatic reset
- Large backlit display is easily visible from a distance and in poor light
- Display and transducer are hard-wired together with a 600 mm cable
- All common units of torque measurement are included
- Pictorial mode selection incorporated for ease of use
- User can select the language they wish to work in (most European languages are included)
- Transducer can be mounted for torque wrench operation in the horizontal or vertical plane
- RS-232-C is included for the output of reading to a printer, PC, data capture unit, SPC software etc
- Optional mounting plate gives greater flexibility of mounting options
- All user-settable parameters are menu selectable from the front panel
- Supplied in a robust carry case with a data transfer lead to connect to a PC or printer
- As standard, all transducers are calibrated in a clockwise direction. For additional counter-clockwise direction order: Part No. PROTEST.CCW



4	PRO-TEST SERIES 2
43218	Pro-Test 60, 1.2 - 60 N·m
43219	Pro-Test 400, 8 - 400 N·m
43220	Pro-Test 1500, 30 - 1,500 N·m

4	ANCILLARY PRODUCTS FOR PRO-TEST
62198.BLK9005	Mounting Bracket
60253	12v DC Power Supply for Series 2
29190	1" x 36 mm socket
29179	3/4" x 36 mm socket
29143	1/2" x 36 mm socket
29083	3/8" x 36 mm socket
PROTEST.CCW	Counter-clockwise calibration when ordered with new unit



Model	Pro-Test 60	Pro-Test 400	Pro-Test 1500	
Part Number	43218	43219	43220	
Socket(s) provided	1/4" to 10 mm Hex 3/8" to 10 mm Hex 1/2" to 10 mm Hex	3/8" to 22 mm Hex 1/2" to 22 mm Hex 3/4" to 22 mm Hex	3/4" to 36 mm Hex	
Dimensions (mm)	ØA	12	12	12
	B	55	55	55
	C	183	183	183
	D	18	18	18
	E	70	70	70
	F	185	185	185
	G	233	233	233
	H	106	106	106
Weight (kg)	6.3	6.4	7.3	

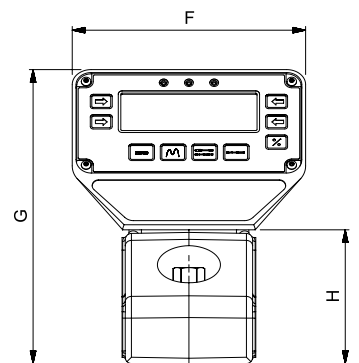
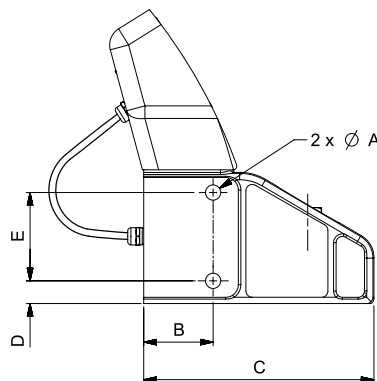



SPARES FOR INSTRUMENTATION PRODUCTS

8	SPARES FOR INSTRUMENTATION PRODUCTS
38876	Rechargeable Battery Pack for Pro-Log, TST & TTT
29610	¼" Female - ½" Male Sleeve Adaptor
29611	½" Female - ¾" Male Sleeve Adaptor
29612	½" Female - 1" Male Sleeve Adaptor
29613	¾" Female - 1" Male Sleeve Adaptor
29614	¾" Female - ½" Male Sleeve Adaptor

4	SERIAL DATA LEAD KIT
60248	Serial Data Lead Kit

Note: Serial Data Lead Kit is not suitable for use with HE Instrument and TruCheck™ 2

60259 | USB to Serial Data Lead (Does not work with USM)
 This kit enables Norbar 'CE Marked' instruments (Post January 1996 ETS, TWA and DTS plus all Pro-Test, TST and TTT) to connect to most PCs.

PART NUMBER SUFFIX SYSTEM

Transducers can be ordered for use with Norbar's current range of instruments (TST, TTT, TTL-HE and T-Box™ 2), and as Industry Standard (mV/V calibrated) for certain display instruments from other manufacturers.

A part number suffix system is used to identify the type of calibration required. For example, a 1,000 N·m Static Transducer for use with a TTT instrument would become part number 50772.LOG.

SUFFIX	USAGE	CERTIFIED IN
.LOG	TST, TTT, TTL-HE & T-Box™ 2	Torque Units
.IND	Instruments of non Norbar manufacture (check with Norbar for suitability) and TST, TTT, TTL-HE & T-Box™ 2	mV/V

Where the transducer suffix .LOG is used, the transducer is calibrated with an instrument, as a system, a calibration certificate is provided in torque units. A full scale mV/V figure is also supplied.

STATIC TRANSDUCER BENCH STANDS

4	BENCH STANDS FOR STATIC TORQUE TRANSDUCERS
50211	Small frame size (10 N·m) ¼" sq.
50212	Small frame size (50 N·m) ⅜" sq.
50213	Small frame size (100/250 N·m) ½" sq.
50220	Large frame size (250/500 N·m) ¾" sq.
50221	Large frame size (1,000/1,500 N·m) 1" sq.
50127.BLK9005*	Extra large size (7,000 N·m) 1½" sq.
52014	¼" Insert for Small Bench Stands
52015	⅜" Insert for Small Bench Stands
52016	½" Insert for Small Bench Stands
52017	¾" Insert for Large Bench Stands
52018	1" Insert for Large Bench Stands

* Dimensions available on request



Model	Small Frame Size	Large Frame Size
Part Number	50211 50212 50213	50220 50221
Dimensions (mm)	A	70
	B	120
	C	150
Weight (kg)	0.8	2.5

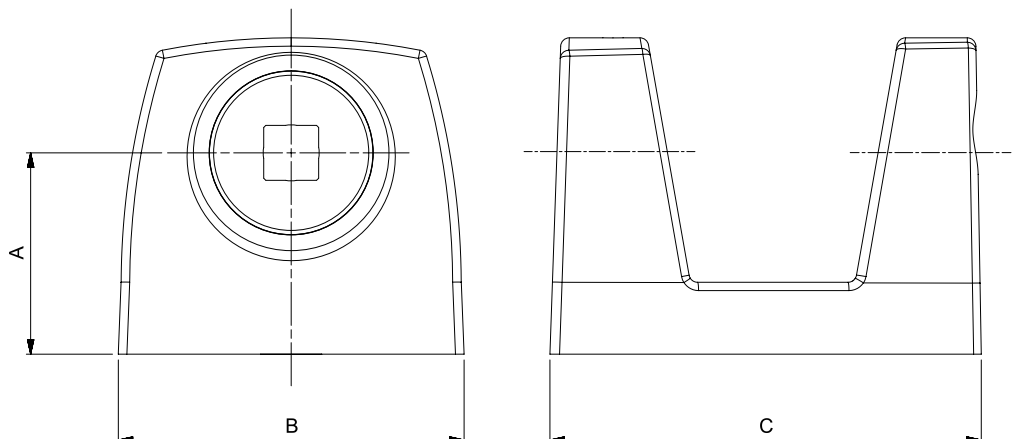

Bench stands ensure the correct mounting of Norbar's Static Torque Transducers up to 7,000 N·m (5,000 lbf·ft).

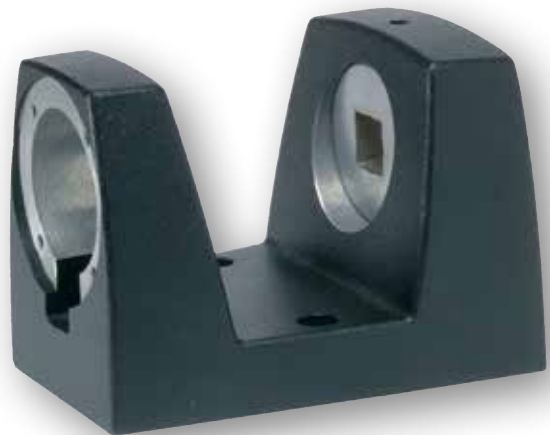



STATIC TRANSDUCERS



The accuracy and quality of the Norbar Static Torque Transducers has made them the first choice of many calibration laboratories throughout the world. Up to 5,000 N·m (5,000 lbf·ft) classified to BS7882:2017, typically better than Class 1 for the primary classification range ($\pm 0.5\%$ of reading from 20% to 100% of full scale).

- Robust, heat treated, alloy steel torsion shaft design
- Designed to ignore non-torsional forces
- Operates in clockwise and counter-clockwise directions
- Calibration up to 100,000 N·m with a UKAS accredited Certificate
- Calibrated in clockwise direction as standard. Counter-clockwise provided on request

- Smart transducers have a built in memory circuit which contains essential information about the transducer. This information can be read by Norbar's TST, TTT, TTL-HE & T-Box™ 2 instruments meaning that when the transducer is connected, it is immediately recognised and ready for use
- Smart transducers can also be used with many other instruments, however these will operate as normal ratio calibrated (mV/V) transducers - the Smart data will not be read

Static Transducers ¼" through to 1"

4	STATIC TRANSDUCERS - 0.1 - 1,500 N·m	
50587.xxx*	0.1 - 1 N·m	¼" M/F
50588.xxx	0.25 - 2.5 N·m	¼" M/F
50589.xxx	0.5 - 5 N·m	¼" M/F
50590.xxx	1 - 10 N·m	¼" M/F
50591.xxx	2.5 - 25 N·m	⅜" M/F
50592.xxx	5 - 50 N·m	⅜" M/F
50593.xxx	10 - 100 N·m	½" M/F
50594.xxx	25 - 250 N·m	½" M/F
50701.xxx	25 - 250 N·m	¾" M/F
50596.xxx	50 - 500 N·m	¾" M/F
50772.xxx	100 - 1,000 N·m	1" M/F
50766.xxx	150 - 1,500 N·m	1" M/F

4	STATIC TRANSDUCERS - 0.1 - 1,000 lbf·ft	
50611.xxx	0.1 - 1 lbf·ft	¼" M/F
50615.xxx	0.5 - 5 lbf·ft	¼" M/F
50618.xxx	1 - 10 lbf·ft	¼" M/F
50620.xxx	2.5 - 25 lbf·ft	⅜" M/F
50836.xxx	5 - 50 lbf·ft	½" M/F
50624.xxx	10 - 100 lbf·ft	½" M/F
50625.xxx	25 - 250 lbf·ft	½" M/F
50702.xxx	25 - 250 lbf·ft	¾" M/F
50627.xxx	50 - 500 lbf·ft	¾" M/F
50773.xxx	100 - 1,000 lbf·ft	1" M/F

4	STATIC TRANSDUCERS - 1 - 1,000 lbf·in	
50610.xxx*	1 - 10 lbf·in	¼" M/F
50612.xxx	2.5 - 25 lbf·in	¼" M/F
50614.xxx	5 - 50 lbf·in	¼" M/F
50617.xxx	10 - 100 lbf·in	¼" M/F
50619.xxx	25 - 250 lbf·in	⅜" M/F
50621.xxx	50 - 500 lbf·in	⅜" M/F
50623.xxx	100 - 1,000 lbf·in	½" M/F

4	STATIC TRANSDUCERS - 10 - 100 ozf·in	
50609.xxx*	10 - 100 ozf·in	¼" M/F

TD2.CCW Alternative calibration direction for transducers up to 1,500 N·m / 1,000 lbf·ft when ordered with new unit

xxx Indicates .LOG or .IND versions, please see page 88.

* .LOG versions not suitable for use with TST, TTT or TTL-HE, purchased pre Feb 2016.



Model	¼" M/F	⅜" M/F	½" M/F	¾" M/F	1" M/F	
Part Number	50587.xxx 50588.xxx 50589.xxx 50590.xxx 50611.xxx 50615.xxx 50618.xxx 50610.xxx 50612.xxx 50614.xxx 50617.xxx 50609.xxx	50591.xxx 50592.xxx 50620.xxx 50619.xxx 50621.xxx	50593.xxx 50594.xxx 50836.xxx 50624.xxx 50625.xxx 50623.xxx	50701.xxx 50596.xxx 50702.xxx 50627.xxx	50772.xxx 50766.xxx 50773.xxx	
Dimensions (mm)	ØA	36	36	36	54	54
	B	33	33	33	42	42
	C	86	90	93	142	147
	D	10	13	16	24	29
	E	30	34	37	46	51
	F	6.5	10	13	22	26
Weight (kg)	0.6	0.6	0.6	1.5	1.7	

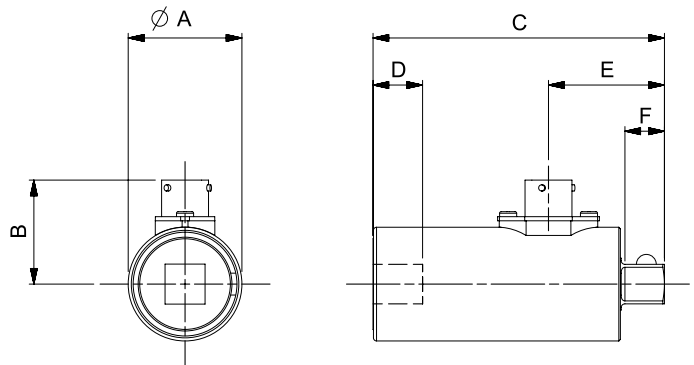



STATIC TRANSDUCERS



Static Transducers 1½" through to 3½" Male to Female (M/F)

4	STATIC TRANSDUCERS - 250 - 7,000 N·m	
50703.xxx	250 - 2,500 N·m	1½" M/F
50791.xxx	300 - 3,000 N·m	1½" M/F
50599.xxx	500 - 5,000 N·m	1½" M/F
50669.xxx@	700 - 7,000 N·m	1½" M/F

4	STATIC TRANSDUCERS - 250 - 5,000 lbf-ft	
50704.xxx	250 - 2,500 lbf-ft	1½" M/F
50630.xxx	500 - 5,000 lbf-ft	1½" M/F

TD5.CCW@ Alternative calibration direction for transducers from 1,501 - 7,000 N·m / 1,001 - 5,000 lbf-ft when ordered with new unit

4	STATIC TRANSDUCERS - 1,000 - 100,000 N·m	
50776.xxx	1,000 - 10,000 N·m	2½" M/F
50797.xxx	2,500 - 25,000 N·m	2½" M/F
50781.xxx	5,000 - 50,000 N·m	2½" M/F
50783.xxx	8,000 - 80,000 N·m	3½" M/F
50816.xxx	10,000 - 100,000 N·m	3½" M/F

4	STATIC TRANSDUCERS - 1,000 - 60,000 lbf-ft	
50777.xxx	1,000 - 10,000 lbf-ft	2½" M/F
50798.xxx	2,500 - 25,000 lbf-ft	2½" M/F
50799.xxx	3,000 - 30,000 lbf-ft	2½" M/F
50782.xxx	6,000 - 60,000 lbf-ft	3½" M/F

TD3.CCW+ Alternative calibration direction for transducers from 7,001 - 100,000 N·m / 5,001 - 100,000 lbf-ft when ordered with new unit

- xxx Indicates .LOG or .IND versions, please see page 88.
- * .LOG versions not suitable for use with TST, TTT or TTL-HE, purchased pre Feb 2016.
- @ UKAS accredited calibration up to 6,000 N·m. A non-accredited value at 7,000 N·m is extrapolated and provided for reference only.
- + UKAS accredited calibration up to 80,000 lbf-ft. A non-accredited value at 100,000 lbf-ft is extrapolated and provided for reference only.



Model	1½" M/F	2½" M/F	3½" M/F	
Part Number	50703.xxx 50791.xxx 50599.xxx 50669.xxx 50704.xxx 50630.xxx	50776.xxx 50797.xxx 50781.xxx 50777.xxx 50798.xxx 50799.xxx	50783.xxx 50816.xxx 50782.xxx	
Dimensions (mm)	ØA	95	130	160
	B	59	80	107
	C	160	209	292
	D	41	59	91
	E	85	114	147
	F	38	57	76
Weight (kg)	4.5	11.5	16.5	

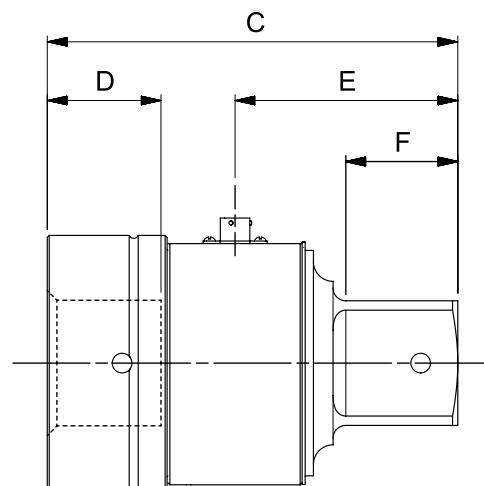
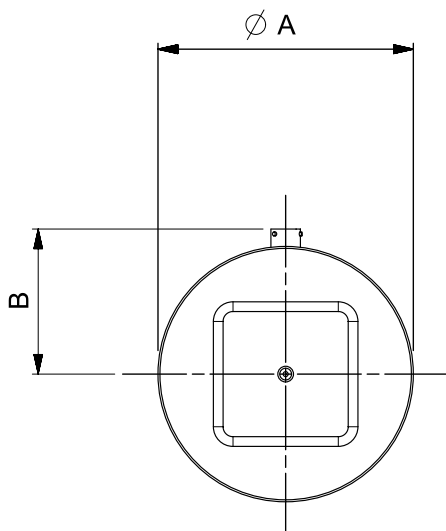



STATIC TRANSDUCERS



Static Transducers 2½" through to 3½" Male to Male (M/M)

4	STATIC TRANSDUCERS - 2,500 - 100,000 N·m	
50603.xxx	2,500 - 25,000 N·m	2½" M/M
50794.xxx	5,000 - 50,000 N·m	3½" M/M
50796.xxx	10,000 - 100,000 N·m	3½" M/M

4	STATIC TRANSDUCERS - 2,500 - 100,000 lbf-ft	
50635.xxx	2,500 - 25,000 lbf-ft	2½" M/M
50795.xxx	5,000 - 50,000 lbf-ft	3½" M/M
50637.xxx+	10,000 - 100,000 lbf-ft	3½" M/M

TD3.CCW+ Alternative calibration direction for transducers from 7,001 - 100,000 N·m / 5,001 - 100,000 lbf-ft when ordered with new unit

4	STATIC TRANSDUCERS - 15,000 - 200,000 N·m	
-	15,000 - 150,000 N·m	4½" M/M
-	20,000 - 200,000 N·m	4½" M/M

- xxx Indicates .LOG or .IND versions, please see page 88.
- * .LOG versions not suitable for use with TST, TTT or TTL-HE, purchased pre Feb 2016.
- @ UKAS accredited calibration up to 6,000 N·m. A non-accredited value at 7,000 N·m is extrapolated and provided for reference only.
- + UKAS accredited calibration up to 80,000 lbf-ft. A non-accredited value at 100,000 lbf-ft is extrapolated and provided for reference only.



Model	2½" M/M	3½" M/M	
Part Number	50603.xxx 50635.xxx	50794.xxx 50796.xxx 50795.xxx 50637.xxx	
Dimensions (mm)	∅A	110	165
	B	82	95
	C	200	271
	D	57	76
	E	100	135
	F	57	76
Weight (kg)	11.5	16.5	

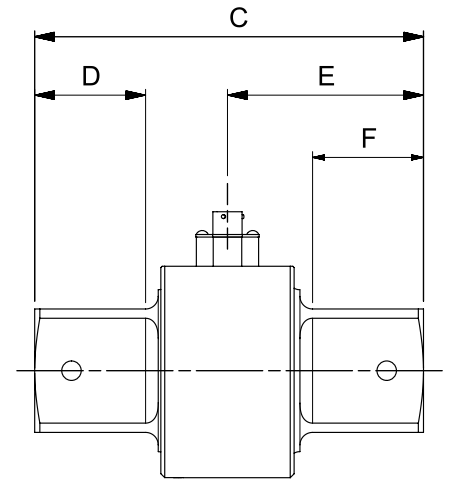
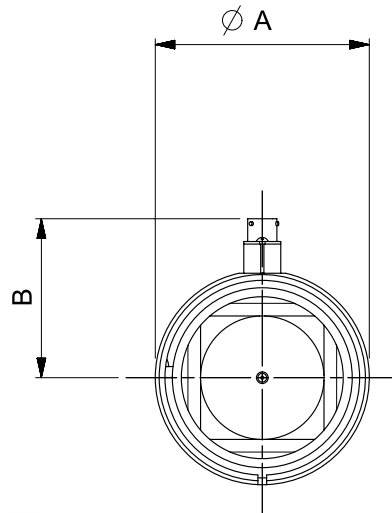

4	STATIC TRANSDUCERS
SECCAL.CW	Secondary calibration in one direction on static transducers with 2½" square drives to extend the range below 10% of the rated capacity, when ordered with new unit
SECCAL.CW+CCW	Secondary calibration in two directions on static transducers with 2½" square drives to extend the range below 10% of the rated capacity, when ordered with new unit
ADDCALPOINTS.NEW	Additional calibration steps below 10% of rated capacity to 2% for transducers up to 7,000 N·m (5,000 lbf-ft) when ordered with new unit



FLANGE MOUNTED TRANSDUCERS (FMT)



FMT 2 N-m

4	FMT
50671.xxx*	0.04 - 2 N-m 1/4" sq. dr. with Joint Simulator
50672.xxx	0.5 - 10 N-m 1/4" sq. dr. with Joint Simulator
50673.xxx	1.25 - 25 N-m 1/4" + 3/8" sq. dr. with Joint Simulator
50677.xxx*	0.4 - 20 lbf-in 1/4" sq. dr. with Joint Simulator
50678.xxx	5 - 100 lbf-in 1/4" sq. dr. with Joint Simulator
50679.xxx	12.5 - 250 lbf-in 1/4" + 3/8" sq. dr. with Joint Simulator

4	FMT
50844.xxx	3 - 60 N-m 1/2" + 3/8" sq. dr. with Joint Simulator
50674.xxx	7.5 - 150 N-m 1/2" + 3/8" sq. dr. with Joint Simulator
50680.xxx	5 - 100 lbf-in 1/2" + 3/8" sq. dr. with Joint Simulator
50675.xxx	20 - 400 N-m 1/2" + 3/4" sq. dr.
50681.xxx	12.5 - 250 lbf-in 1/2" + 3/4" sq. dr.

4	FMT
50676.xxx	30 - 1,500 N-m 1/2", 3/4" + 1" sq. dr.
50682.xxx	20 - 1,000 lbf-in 1/2", 3/4" + 1" sq. dr.
TD1.CCW	Counter-clockwise calibration for FMT & STB when ordered with new unit

xxx Indicates .LOG or .IND versions, please see page 88.
 * If using this transducer with a Series 1 TST or TTT (Part No.s 43198 - 43201) or a Pro-Log Display instrument, please contact Norbar.
 Includes integral transducer lead with connector to suit TST, TTT and T-Box™ 2



FMT 400 N-m

FMT 1,500 N-m

Model	FMT (2 N-m - 25 N-m)	FMT (60 N-m - 400 N-m)	FMT (1,500 N-m)
Part Number	50671.xxx 50672.xxx 50673.xxx 50677.xxx 50678.xxx 50679.xxx	50844.xxx 50674.xxx 50680.xxx 50675.xxx 50681.xxx	50676.xxx 50682.xxx
Dimensions (mm)	ØA	5.5	8.5
	ØB	64	90
	C	63	65
Weight (kg)	0.8 (2 N-m & 20 lbf-in) 0.8 (10 N-m & 100 lbf-in) 0.9 (25 N-m & 250 lbf-in)	3.3 (60 N-m, 150 N-m & 100 lbf-ft) 1.5 (400 N-m) 2.7 (250 lbf-ft)	7.0

Flange Mounted Transducers (FMT) incorporate mounting points for securely fixing the transducer to the working surface. The transducer lead is also included and is fitted with a high quality connector, suitable for attachment to TST, TTT and T-Box™ 2 instruments.

4	FMT (Ancillary Section)
50539	2 N-m Joint Simulator (also fits TST)
50540	10 N-m Joint Simulator (also fits TST)
50541	25 N-m Joint Simulator (also fits TST)
50845	60 N-m Joint Simulator
50692	150 N-m Joint Simulator
50819	400 N-m Joint Simulator
52236	1/4" Hexagon - 1/4" Square Drive Adaptor
52237	1/4" Hexagon - 3/8" Square Drive Adaptor
52251	3/8" Female Square - 22 mm Bi-Square Adaptor
52246	1/2" Female Square - 22 mm Bi-Square Adaptor
52245	3/4" Female Square - 22 mm Bi-Square Adaptor
52254	1/2" Female Square - 35 mm Bi-Square Adaptor
52241	3/4" Female Square - 35 mm Bi-Square Adaptor
52242	1" Female Square - 35 mm Bi-Square Adaptor



FMT Mounting Brackets

4	FMT Mounting Brackets
62221.BLK9005	FMT Mounting Bracket 2 - 400 N-m
62220.BLK9005	FMT Mounting Bracket 150 - 1,500 N-m

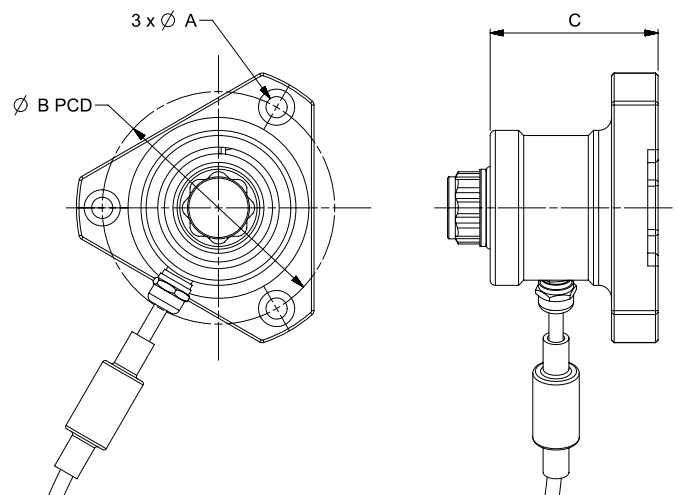



ROTARY TRANSDUCERS



Rotary transducers are designed to measure the torque from continuously rotating shafts such as impulse power tools and certain non-impulse tools with a severe clutch action.

This range offers class-leading performance with impulse tools and will be supplied with a UKAS accredited calibration certificate from Norbar's laboratory.

These transducers are known as Smart transducers. They have built-in intelligence in the form of a memory circuit which contains essential information about the transducer which can be read by the appropriate type of instrument (TST, TTT, TTL-HE & T-Box™ 2), thus reducing set-up time.

They will also work with instruments that cannot read the memory information, by inputting the relevant calibration details manually.

Note: Not for use with Impact Tools.

Angle measurement also available.



4	ROTARY TRANSDUCERS
50708.xxx	0.25 - 5 N·m ¼" M/F Hex
50709.xxx	1 - 20 N·m ¼" M/F Hex
50710.xxx	1 - 20 N·m ¼" M/F sq. dr.
50719.xxx	0.75 - 15 lbf·ft ¼" M/F sq. dr.
50711.xxx	3.75 - 75 N·m ⅜" M/F sq. dr.
50720.xxx	2.5 - 50 lbf·ft ⅜" M/F sq. dr.
50712.xxx	10 - 200 N·m ½" M/F sq. dr.
50721.xxx	7.5 - 150 lbf·ft ½" M/F sq. dr.

4	ROTARY TRANSDUCERS
50713.xxx	12.5 - 250 N·m ¾" M/F sq. dr.
50722.xxx	10 - 200 lbf·ft ¾" M/F sq. dr.
50714.xxx	25 - 500 N·m ¾" M/F sq. dr.
50723.xxx	15 - 300 lbf·ft ¾" M/F sq. dr.
50715.xxx	75 - 1,500 N·m 1" M/F sq. dr.
50724.xxx	50 - 1,000 lbf·ft 1" M/F sq. dr.
TD2.CCW	Counter-clockwise calibration.

Angle options available, contact Norbar.

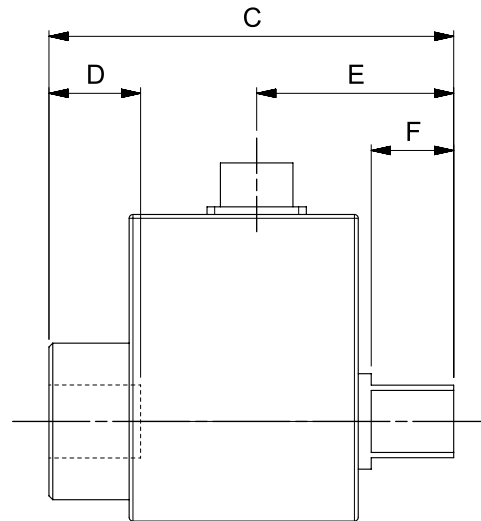
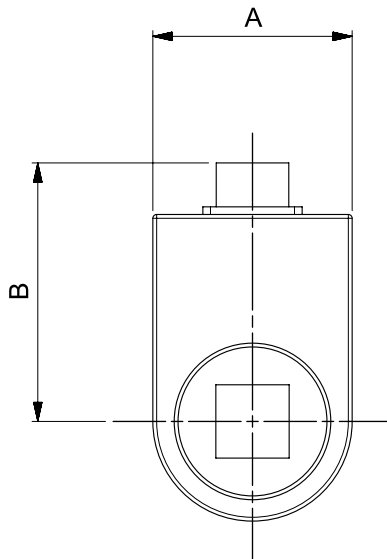

Model	¼" M/F Hex	¼" M/F sq. dr.	⅜" M/F sq. dr.	½" M/F sq. dr.	¾" M/F sq. dr.	1" M/F sq. dr.	
Part Number	50708.xxx 50709.xxx	50710.xxx 50719.xxx	50711.xxx 50720.xxx	50712.xxx 50721.xxx	50713.xxx 50714.xxx 50722.xxx 50723.xxx	50715.xxx 50724.xxx	
Dimensions (mm)	A	30	30	30	42	52	63
	B	58	58	62	67	73	79
	C	116	72	77	87	106	125
	D	N/A	10	13	16	24	29
	E	49	33	36	42	51	61
	F	26	7	11	15	21	26
Weight (kg)	0.2	0.2	0.2	0.4	0.8	1.5	



ANNULAR TRANSDUCERS



4 ANNULAR TRANSDUCERS FOR HT/ET/EBT/PTS/PTM-92

50753.xxx	270 - 2,700 N·m 1" sq. dr.
50793.xxx	400 - 4,000 N·m 1" sq. dr.

Standard Calibration is performed loading counter-clockwise only.



4 ANNULAR TRANSDUCERS FOR HT/ET/EBT/PTS/PTM-119 SERIES

50755.xxx	450 - 4,500 N·m 1½" sq. dr.
50756.xxx	600 - 6,000 N·m 1½" sq. dr.

Standard calibration is performed loading counter-clockwise only.

These Annular Transducers are designed to fit directly to Norbar torque multipliers and will accurately measure the torque output from the gearbox, via a display instrument (instrument supplied separately, see pages 83 - 84 & 86).

- Up to 6,000 N·m classified to BS7882:2017, typically better than Class 1 for the primary classification range (±0.5% of reading from 20% to 100% of full scale)
- Robust heat treated alloy steel torsion tube design
- Designed to ignore non-torsional forces
- Smart transducers have a built in memory circuit which contains essential information about the transducer. This information can be read by Norbar's TST, TTT, TTL-HE & T-Box™ 2 instruments meaning that when the transducer is connected, it is immediately recognised and ready for use
- Smart transducers can also be used with many other instruments, however, these will operate as normal ratio calibrated (mV/V) transducers - the Smart data will not be read

Model	Annular Transducers for use with	
	HT/ET/EBT/PTS/PTM-92	HT/ET/EBT/PTS/PTM-119
Part Number	50753.xxx 50793.xxx	50755.xxx 50756.xxx
Dimensions (mm)	A	58
	B	88
	∅C	73
Weight (kg)	4.6	7.9

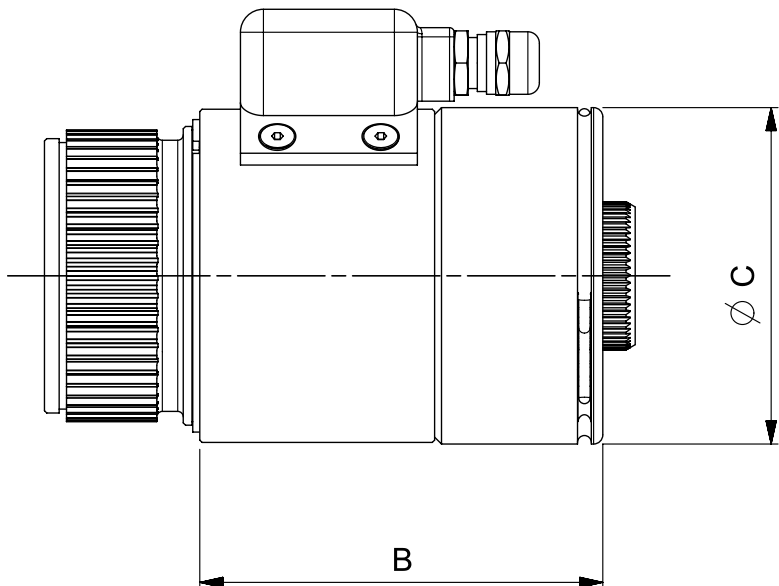
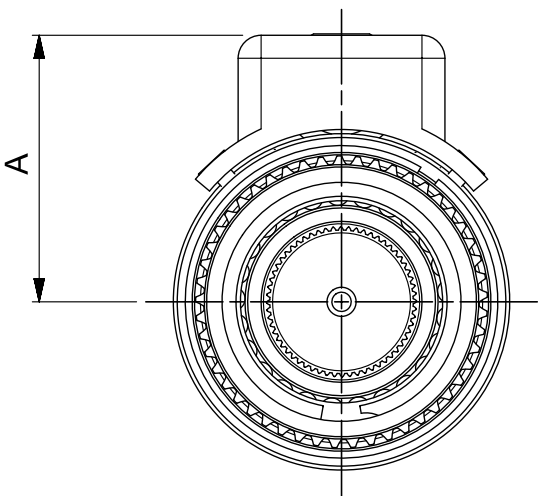



ANNULAR TRANSDUCERS



4 ANNULAR TRANSDUCERS FOR STANDARD SERIES GEARBOX

Suitable for PT1, PT1A and PT2

50638.xxx	100 - 1,000 N·m ¾" sq. dr.
50648.xxx	100 - 1,000 lbf-ft ¾" sq. dr.

Suitable for heavy duty HT2, PT1, PT1A and PT2

50639.xxx	150 - 1,500 N·m 1" sq. dr.
50649.xxx	150 - 1,500 lbf-ft 1" sq. dr.

TD2.CCW	Alternative calibration direction for transducers up to 1,500 N·m / 1,000 lbf-ft when ordered with new unit
---------	---

Suitable for HT5 and PT5

50640.xxx	250 - 2,500 N·m 1" sq. dr.
50650.xxx	250 - 2,500 lbf-ft 1" sq. dr.
50641.xxx	350 - 3,500 N·m 1" sq. dr.

Suitable for HT6 and PT6

50700.xxx	350 - 3,500 N·m 1½" sq.dr.
-----------	----------------------------

Suitable for HT7 and PT7

50643.xxx	500 - 5,000 N·m 1½" sq. dr.
50652.xxx	500 - 5,000 lbf-ft 1½" sq. dr.

TD5.CCW@	Alternative calibration direction for transducers from 1,501 - 7,000 N·m / 1,001 - 5,000 lbf-ft when ordered with new unit
----------	--

Model	Annular Transducers for use with Standard Series Multipliers		
Part Number	50638.xxx	50640.xxx	
	50648.xxx	50650.xxx	50643.xxx
	50639.xxx	50641.xxx	50652.xxx
	50649.xxx	50700.xxx	
Dimensions (mm)	∅A	108	119
	B	60	65
Weight (kg)		1.4	2.6

4 ANNULAR TRANSDUCERS FOR STANDARD SERIES GEARBOX

Suitable for HT9 and PT9

50644.xxx	1,000 - 10,000 N·m 1½" sq. dr.
50653.xxx	700 - 7,000 lbf-ft 1½" sq. dr.

Suitable for HT11 and PT11

50645.xxx	2,000 - 20,000 N·m 2½" sq. dr.
50654.xxx	1,500 - 15,000 lbf-ft 2½" sq. dr.

Suitable for HT12 and PT12

50764.xxx	3,500 - 35,000 N·m 2½" sq. dr.
50765.xxx	2,500 - 25,000 lbf-ft 2½" sq. dr.

Suitable for HT13 and PT13

50646.xxx	5,000 - 50,000 N·m 2½" sq. dr.
-----------	--------------------------------

Suitable for PT14

50647.xxx	10,000 - 100,000 N·m 3½" sq. dr.
-----------	----------------------------------

TD4.CCW	Alternative calibration direction for transducers from 7,001 - 100,000 N·m / 5,001 - 75,000 lbf-ft when ordered with new unit
---------	---

Suitable for PT18.MTS

-	30,000 - 300,000 N·m
---	----------------------

Standard calibration is performed loading counter-clockwise only.

@ UKAS accredited calibration up to 6,000 N·m. A non-accredited value at 7,000 N·m is extrapolated and provided for reference only.



PT 18 fitted with 300,000 N·m Annular Transducer and square drive

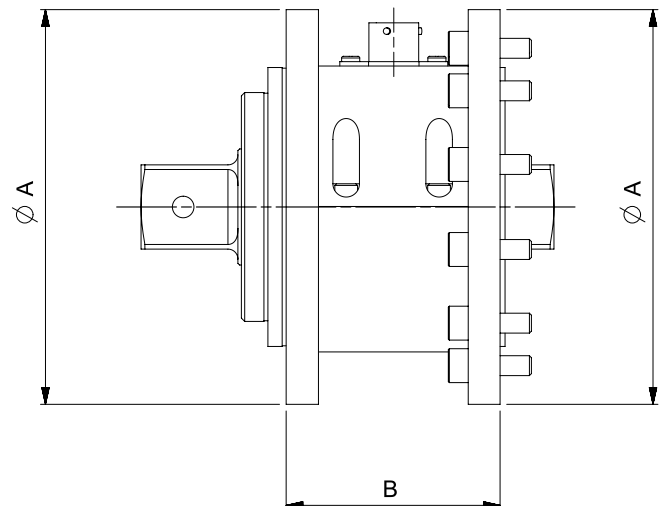



ANNULAR TRANSDUCERS



4 TORQUE & ANGLE ANNULAR TRANSDUCERS - FIXED CONNECTOR

Suitable for heavy duty PT1, PT1A and PT2

50820.LOGA*	100 - 1,000 N·m ¾" sq. dr.
50821.LOGA**	150 - 1,500 N·m 1" sq. dr.

* Can only be used with remote/plain sleeve motors i.e. not a standard PT handle, due to cable interference
 * Only fits to PT with HD final stage carrier having 1" female sq. dr.

Suitable for HT5 and PT5

50822.LOGA	350 - 3,500 N·m 1" sq. dr.
------------	----------------------------

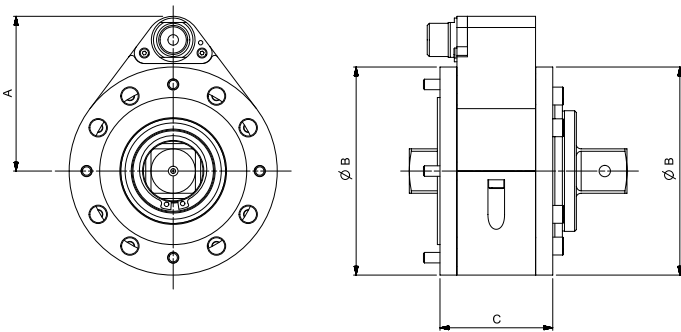

Model	Torque & Angle Annular Transducers with Fixed Connector	
Part Number	50820.LOGA 50821.LOGA 50822.LOGA	
Dimensions (mm)	A	89
	ØB	119
	C	65
Weight (kg)	1.4	



Fixed Connector

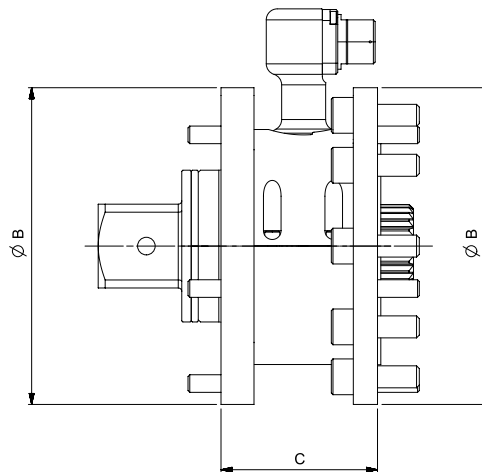
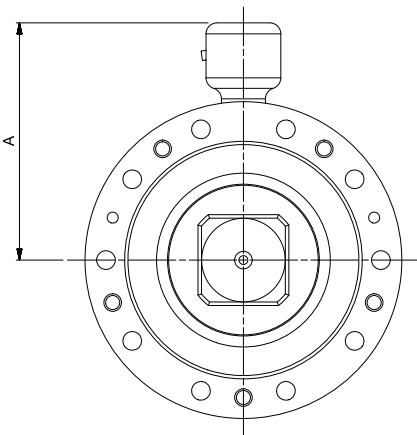

180° Swivel Connector

4 TORQUE & ANGLE ANNULAR TRANSDUCERS - 180° SWIVEL CONNECTOR

Suitable for HT7 and PT7

50834.LOGA	500 - 5,000 N·m 1½" sq. dr.
------------	-----------------------------

Suitable for HT9 and PT9

50824.LOGA	1,000 - 10,000 N·m 1½" sq. dr.
------------	--------------------------------

Suitable for HT11 and PT11

50825.LOGA	2,000 - 20,000 N·m 2½" sq. dr.
------------	--------------------------------

Suitable for HT12 and PT12

50826.LOGA	3,500 - 35,000 N·m 2½" sq. dr.
------------	--------------------------------

Suitable for HT13 and PT13

50827.LOGA	5,000 - 50,000 N·m 2½" sq. dr.
------------	--------------------------------

Suitable for HT14 and PT14
 PT13 & PT14 require special front cover plate with added dowel clearance holes

Suitable for HT15 and PT15

50832.LOGA	15,000 - 150,000 N·m 4½" sq. dr.
------------	----------------------------------

Suitable for HT16 and PT16

50829.LOGA	20,000 - 200,000 N·m 5" sq. dr.
------------	---------------------------------

Suitable for HT17 and PT17

50830.LOGA	25,000 - 250,000 N·m 6" sq. dr.
------------	---------------------------------

Suitable for HT18 and PT18

50831.LOGA	30,000 - 300,000 N·m 6" sq. dr.
------------	---------------------------------

Model	Torque & Angle Annular Transducers with Swivel Connector										
	5,000 N·m	10,000 N·m	20,000 N·m	35,000 N·m	50,000 N·m	100,000 N·m	150,000 N·m	200,000 N·m	250,000 N·m	300,000 N·m	
Part Number	50834.LOGA	50824.LOGA	50825.LOGA	50826.LOGA	50827.LOGA	50828.LOGA	50832.LOGA	50829.LOGA	50830.LOGA	50831.LOGA	
Dimensions (mm)	A	108	120	140	151	186	186	*	*	*	289
	ØB	144	178	212	248	315	315	*	*	*	520
	C	144	184	212	240	315	315	*	*	*	520
Weight (kg)	7.0	10.0	15.0	29.3	43.5	46.6	*	*	*	149.5	

* Available on request



ANNULAR TRANSDUCERS



4 ANNULAR TRANSDUCERS FOR 72 mm SERIES GEARBOX (HT & PT) (Not suitable for PTS/PTM tools)

Suitable for PT-72 mm Remote Series and HT-72

50666.xxx	100 - 1,000 N·m
50667.xxx	150 - 1,500 N·m
50668.xxx	200 - 2,000 N·m

Standard calibration is performed loading counter-clockwise only.

4 ANNULAR TRANSDUCERS FOR PTS/PTM 72

Suitable for PTS/PTM-72 mm Series

50840.xxx	100 - 1,000 N·m
50841.xxx	150 - 1,500 N·m
50842.xxx	200 - 2,000 N·m
50846.LOGA	100 - 1,000 N·m with Angle



Model	Annular Transducers for use with 72 mm Series Multipliers	Annular Transducers for use with 72 mm Series Multipliers	
Part Number	50666.xxx 50667.xxx 50668.xxx 50840.xxx 50841.xxx 50842.xxx	50846.LOGA	
Dimensions (mm)	A	58	85
	B	84	93
	∅C	72	73
Weight (kg)	1.5	3.1	

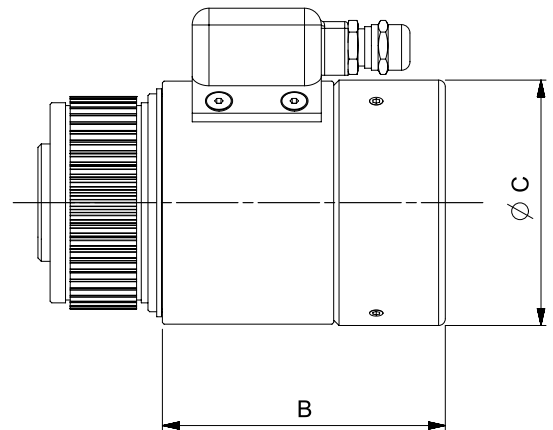
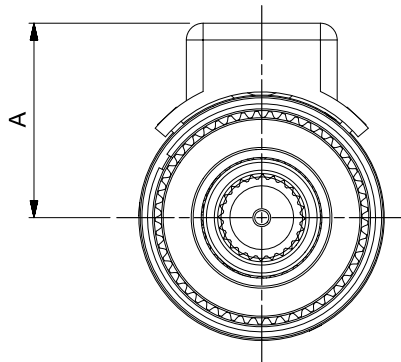

Torque and Angle Annular Transducer Note:

- 5,000 N·m and above include dowels on both mounting faces
- Angle resolution < 1° when used with T-Box XL™
- CW+CCW calibration is standard
- Use 60308.xxx series lead for direct connection to T-Box XL™ for torque and angle/turns monitoring and storage
- PT square drive and other parts may require removal to fit transducer
- All the above are standard construction. Harsh Environment models are available on request
- '.INDA' versions are available on request

Note: PTS™ and reactions with dowel holes can be supplied at an extra cost on request. Request details on PneuTorque® Type '.XD'

4 ANNULAR TRANSDUCERS

SECCAL.CW	Secondary calibration in one direction on annular transducers for HT/PT9 & HT/PT11 to extend the range below 10% of the rated capacity, when ordered with new unit
SECCAL.CW+CCW	Secondary calibration in two directions on annular transducers for HT/PT9 & HT/PT11 to extend the range below 10% of the rated capacity, when ordered with new unit
ADDCALPOINTS.NEW	Additional calibration steps below 10% of rated capacity to 2% for transducers up to 7,000 N·m (5,000 lbf·ft) when ordered with new unit



TRANSDUCER LEADS



4	TRANSDUCER LEADS
60216.200	PRO-LOG, TST, TTT, T-Box XL & T-Box 2 to 10 Way Transducer for use with Norbar Rotary Transducers
60217.200	PRO-LOG, TST, TTT, T-Box XL & T-Box 2 to 6 Way Transducer for use with Norbar Static & Annular Transducers
60223.200	PRO-LOG, TST, TTT, T-Box XL & T-Box 2 to no connector
60224.200	10 Way Transducer to no connector
60225.200	6 Way Transducer to no connector
51067.225	ETS to Transducer (Pre 1994) + 5 way (60055)
60152.225	ETS to Transducer (Post 1994) + 5 way (60163)
60308.400	PRO-LOG, TST, TTT, T-Box XL & T-Box 2 to Torque & Angle Annular Transducers
60308.600	PRO-LOG, TST, TTT, T-Box XL & T-Box 2 to Torque & Angle Annular Transducers
60308.1000	PRO-LOG, TST & TTT to Torque & Angle Annular Transducers

Other lengths can be ordered at an additional cost.
 Note: The system should be calibrated with the increased length lead, as calibration may be effected.
 Note: The maximum permissible cable length is 15 m for TST or TTT. Contact Norbar for further details.

If ordering a static, annular or rotary transducer you will also require a corresponding lead (see list on the right). To comply with the latest calibration standards, most new transducer leads will have a suffix to indicate the length in centimetres.

ISO 3000 LOADER

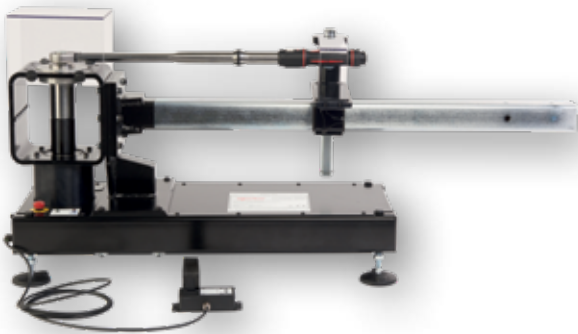

4	TORQUE WRENCH LOADERS
20505	Loader, ISO 3,000 N·m
20506	Motorised ISO 3,000 N·m



Model	ISO 3000 N·m	Motorised ISO 3000 N·m
Part Number	20505	20506
Dimensions (mm)	A	451
	B	2,440
	C	1,232
	D	534
Weight (kg)	55.0	40.0

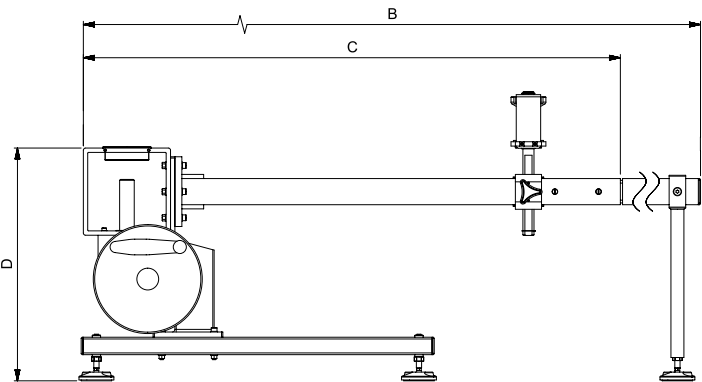
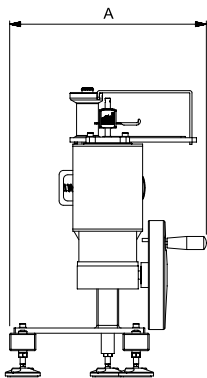



TORQUE WRENCH CALIBRATOR - MANUAL



Torque Wrench Calibrator (TWC) 400 N-m Manual

- Enables torque wrench calibration or testing in accordance with ISO 6789-2:2017 if used with T-Box™ 2
- Also in accordance with BS EN 26789:2003, ISO 6789-1:2017
- Counterbalance Reaction system is designed to support the weight of the wrench so that the weight does not become a parasitic force within the calibration system. The floating nature of the support means that the wrench is able to find its own natural level rather than being constrained as in many other loading devices. Any such constraint will be a parasitic force within the system (Patents apply)
- Lightweight alloy construction ensures the TWC is easily transported, making it well suited for mobile laboratory applications

- Two speed gearbox designed for a sufficient balance of speed and control by allowing for both fast loading of the torque wrench and a slower more precise loading
- Works with Flange Mounted Transducers, Static Transducers (when using part number: 60318), T-Box™ 2, TST, TTT and Pro-Test (when using part number: 60323)
- During calibration the TWC maintains a fixed position on the handle of the torque wrench
- Rotating transducer design ensures that the load is applied 90° to the torque wrench handle. The benefit of this precise alignment is that forces are applied squarely to the load point of the handle
- Any Transducer must not be used below 5% of its capacity when used with TWC

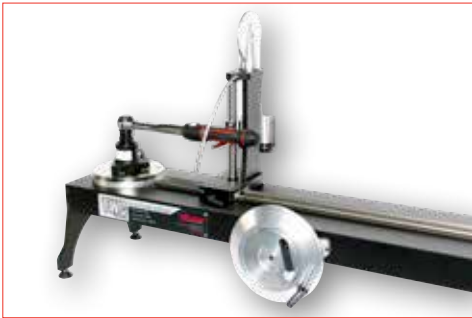

Torque Wrench Calibrator (TWC) Manual shown with a Flange Mounted Transducer and a Model 100 torque wrench (not included)

4	TORQUE WRENCH CALIBRATOR (TWC)
60331	Torque Wrench Calibrator 400 N-m Manual
60332	Torque Wrench Calibrator 1,500 N-m Manual

Model	TWC 400	TWC 1500
Part Number	60331	60332
Wrench Length (Torque Radius)	Min	135
	Max	750
Dimensions (mm)	A	620
	B	330
	C	395
	D	487
	E	1,010
Weight (kg)	35.0	40.0

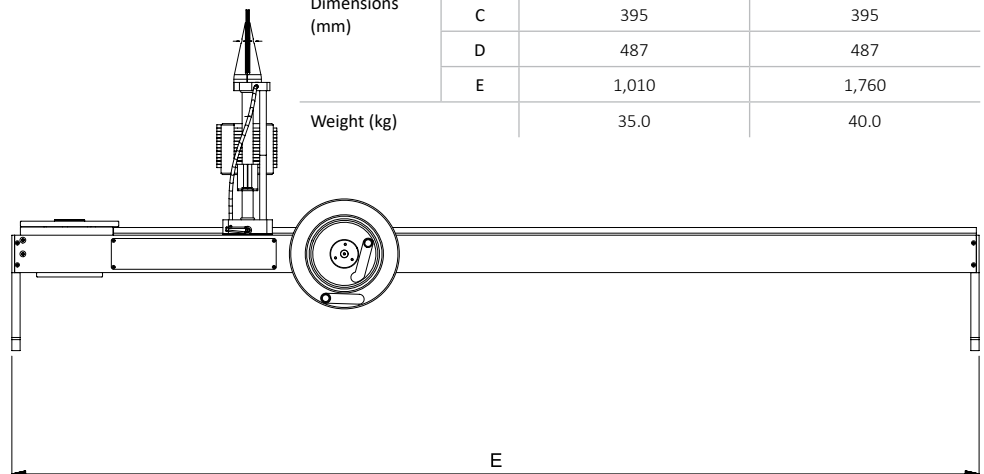
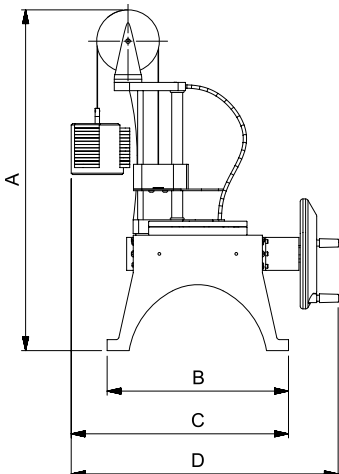

Patented in the UK, Germany, France and Italy (EP2864745) and in the USA (US9921122).



TORQUE WRENCH CALIBRATOR - ANCILLARIES

There are a wide range of accessories available for the TWC that will allow the user greater flexibility.

- 60322 Quick Release FMT Kit allows for a more streamlined and efficient calibration laboratory
- 60324 Hexagon Adaptor Kit for use with the TWC Manual allows users to speed up the workflow by implementing their own solution to rapidly manoeuvre the wrench up to the reaction point
- 60330 Offset Angle Plate Kit allows for greater flexibility when calibrating fixed head torque wrenches

8	TWC ANCILLARIES
60318	Static Transducer Support Kit
60319	Short Length Reaction Post
60322	Quick Release FMT Kit
60323	Pro-Test and Static Torque Block Adaptor Kit
60324	Hexagon Adaptor Kit
60327	FMT 25 Adaptor Kit
60329	3 kg Mass Weight
60330	Offset Angle Plate Kit
29214	1" Male to 3/4" Female Flanged Square Drive Adaptor
29215	1" Male to 1/2" Female Flanged Square Drive Adaptor
29216	1" Male to 3/8" Female Flanged Square Drive Adaptor
29217	1" Male to 1/4" Female Flanged Square Drive Adaptor



60318 Static Transducer Support Kit and 60319 Short Length Reaction Post



60322 Quick Release FMT Kit



60330 Offset Angle Plate Kit



60323 Pro-Test and Static Torque Block Adaptor Kit



29214 Flanged Square Drive Adaptor



60324 Hexagon Adaptor Kit



60329 3 kg Mass Weight



TORQUE WRENCH CALIBRATOR - AUTO



For a complete torque wrench calibration system, just add the transducer range appropriate for the wrenches you wish to calibrate and accessories from page 100.

- Enables torque wrench calibration or testing in accordance with ISO 6789:2017 Part 1 and 2
- Counterbalance Reaction system is designed to support the weight of the wrench so that the weight does not become a parasitic force within the calibration system. The floating nature of the support means that the wrench is able to find its own natural level rather than being constrained as in many other loading devices. Any such constraint will be a parasitic force within the system (Patents apply)
- Lightweight alloy construction ensures the TWC is easily transported, making it well suited for mobile laboratory applications
- Works with Flange Mounted Transducers and Static Transducers
- During calibration, the TWC maintains a fixed position on the handle of the torque wrench
- Rotating transducer design ensures that the load is applied 90° to the torque wrench handle. The benefit of this precise alignment is that forces are applied squarely to the load point of the handle
- Supplied with a powerful yet simple touchscreen User Interface (UI) (keyboard and mouse also supported if desired)
- Flexible tool template system; minimises number of templates required to cover a wide range of tools, aiding efficient use
- Programmable calibration workflow for each template, can be pre-set to ISO compliant flow for the given tool for a faster set-up or can also support bespoke workflows

- Calibration job management; book calibrations, track progress of previous bookings and resume them
- Automated management of calibration and conformance workflows for non-indicating tools
- Intelligent rate control system ensures fast cycling of tools while maintaining compliance with 2017 standards
- Environmental monitoring (humidity/temperature) to ensure compliance with calibration standards
- Automated management of uncertainty data for ISO 6789-2:2017 calibrations, guiding the user through the process using dynamically generated instructions based on the current tool's ISO classification and workflow
- Inbuilt data analysis and certification generation seamlessly move from calibration/conformance procedure to certificate generation, no third-party software required
- A substantial amount of inbuilt storage allowing for several years' worth of calibration data through normal use
- The TWC control Box is supported by a UKAS accredited certificate of calibration, we remain one of the few manufacturers in the world that issue a UKAS accredited calibration certificate both for the instrument and for the torque transducer. In doing so, customers can swap combinations of instrument and transducer while retaining complete traceability
- Any Transducer must not be used below 5% of its capacity when used with TWC Auto

5	TORQUE WRENCH CALIBRATOR (TWC)
60312	Torque Wrench Calibrator 400 N-m Auto
60313	Torque Wrench Calibrator 1,500 N-m Auto



Torque Wrench Calibrator (TWC) Auto shown with a Professional Model 200 and a Static Transducer with support kit (not included)



TORQUE WRENCH CALIBRATOR - AUTO



Software Screen Shots:



Main menu



Tool template editor



Calibration job booking / editor



Tool cycling and adjustment

Model	TWC Auto 400	TWC Auto 1500
Part Number	60312	60313
Wrench Length (Torque Radius)	Min	135
	Max	750
Dimensions (mm)	A	620
	B	330
	C	395
	D	1,019
Weight (kg)	40.0	45.0

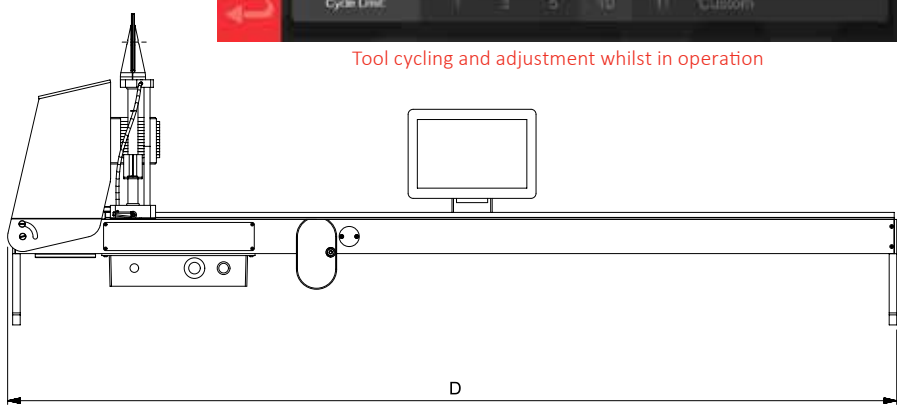
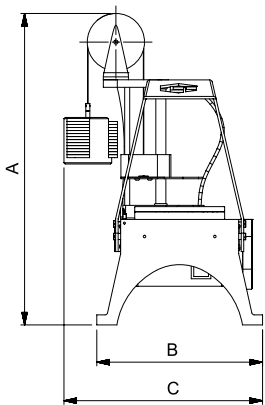

Tool cycling and adjustment whilst in operation

Patented in the UK, Germany, France and Italy (EP2864745) and in the USA (US9921122).



TEST RIGS AND FIXTURES

The Norbar Joint Simulation Rundown Assemblies are designed to simulate the working conditions of screwed or bolted joints. Used in conjunction with a Norbar transducer and display instrument, the output of torque controlled power tools can be measured against a range of simulated joint rates, from hard through to soft.



4 JOINT SIMULATION RUNDOWN ASSEMBLIES

50313	0.2 - 2 N·m (2 - 20 lbf·in)
50251	2 - 10 N·m (20 - 100 lbf·in)
50252	5 - 50 N·m (5 - 50 lbf·ft)
50253	10 - 100 N·m (10 - 100 lbf·ft)
50254*	100 - 500 N·m (100 - 500 lbf·ft)

The above are for use with Norbar static square to square transducers and bench stands, see page 89.

* To be used with large frame size bench stands, all others to be used with small frame bench stands.

50693	10 - 140 N·m (10 - 100 lbf·ft)
50694	100 - 700 N·m (70 - 500 lbf·ft)

The above are for use with the Norbar Smart Torque Block (STB) 1000.



Power Tool Test Fixture shown with TruCheck™ 2 Plus 1100 (not included) and adapter plate 39994 (not included)

4 WASHER STACKS FOR JOINT SIMULATION RUNDOWN ASSEMBLIES

50175	0.2 - 0.7 N·m Stack A for use with 50313
50176	0.5 - 1.4 N·m Stack B for use with 50313
50177	1.2 - 2.8 N·m Stack C for use with 50313
50178	2 - 6 N·m Stack D for use with 50251
50179	6 - 12 N·m Stack E for use with 50251
50695	5 - 30 N·m Stack A for use with 50252
50696	20 - 50 N·m Stack B for use with 50252
50697	50 - 70 N·m Stack C for use with 50252
50180	10 - 50 N·m Stack F for use with 50253 and 50693
50192	30 - 100 N·m Stack G for use with 50253 and 50693
50698	80 - 140 N·m Stack H for use with 50253 and 50693

4 POWER TOOL TEST FIXTURE FOR TRUCHECK PLUS 1000 AND 2000

50757	Power Tool Test Fixture for TruCheck Plus 1000
50774	Power Tool Test Fixture for TruCheck Plus 2000
50758	1,000 N·m Joint Simulator Rundown Assembly
50775	2,000 N·m Joint Simulator Rundown Assembly
39994	TruCheck 2 Power Tool Test Fixture Adapter Plate Kit

Model	Power Tool Test Fixture for TruCheck Plus 1000	Power Tool Test Fixture for TruCheck Plus 2000
Part Number	50757	50774
Dimensions (mm)	A	190
	B	211
	C	550
	D	180
	E	205
	F	135
	ØG	11
Weight (kg)	19.1	19.1

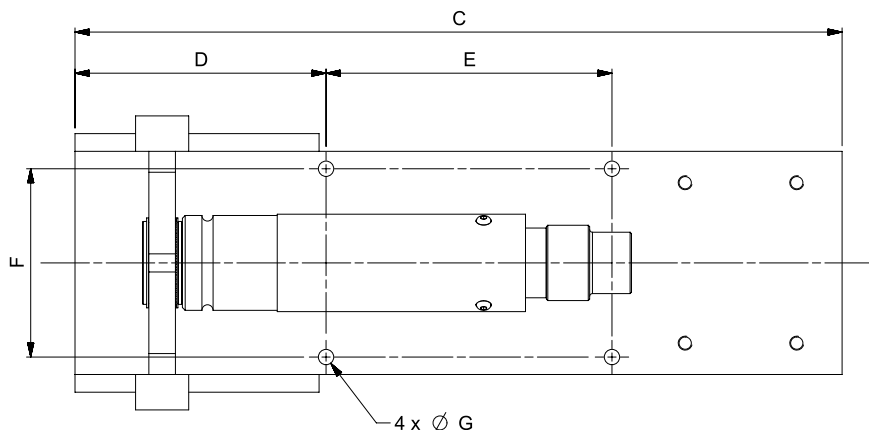
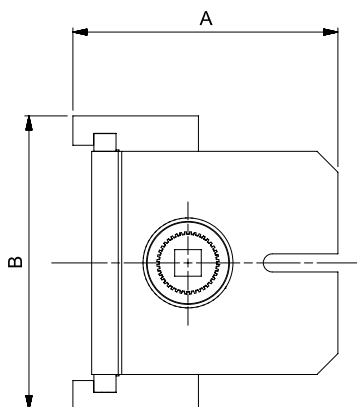



TEST RIGS AND FIXTURES

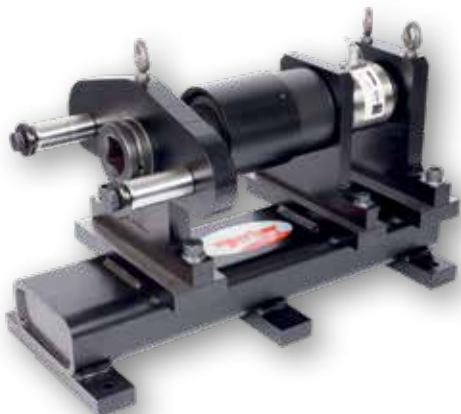

Power Tool Test Rig shown with 1½" M/F Static Transducer (not included)

4	ET/EBT/PT POWER TOOL TEST RIG
50800	7,000 N·m ET, EBT, PT Power Tool Test Rig (supplied with the 8 reaction plates on page 105 (excluding blank reaction plate) and ¾", 1" and 1½" sq. dr. adaptors)
50803	7,000 N·m ET, EBT, PT Power Tool Test Rig without Reaction Plates (supplied with ¾", 1" and 1½" sq. dr. adaptors)

Note: The static transducer 50669.LOG does not come supplied as standard with the tool test rig. The standard range of 700 - 7,000 N·m will not cover the full powered multiplier range, additional calibration may be required, please see below:

ADDCALPOINTS.NEW

Additional calibration steps below 10% of rated capacity to 2% for transducers up to 7,000 N·m (5,000 lbf·ft) when ordered with new unit

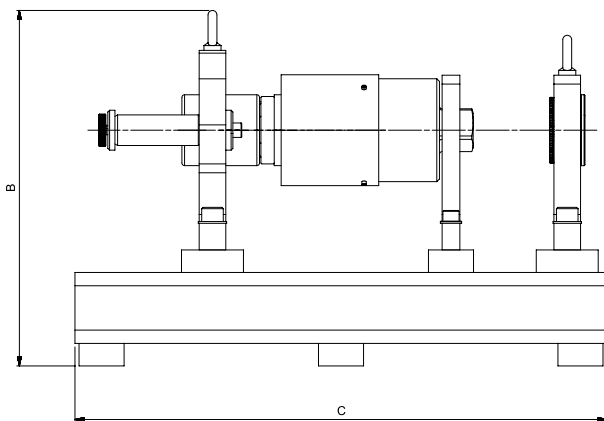
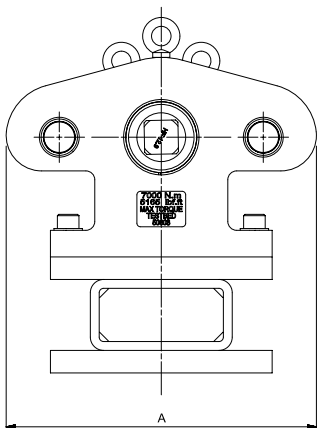

Model	Power Tool Test Rig
Part Number	50800 50803
Dimensions (mm)	A 350
	B 401
	C 600
Weight (kg)	TBC



Universal Tool Test Rig (1½" M/F Static Transducer required (not included))

Model	Universal Tool Test Rig
Part Number	50801, 50804
Dimensions (mm)	A 180
	B 350
	C 415
	D 550
Weight (kg)	73.0

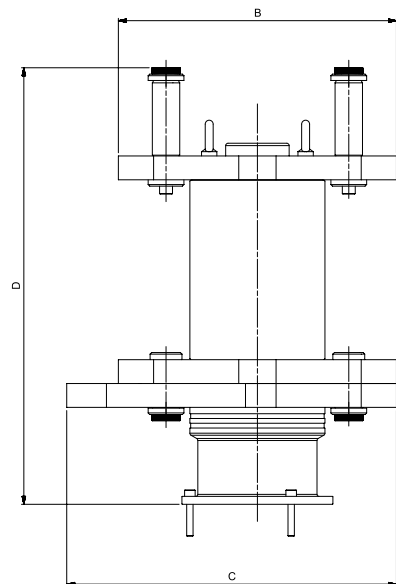
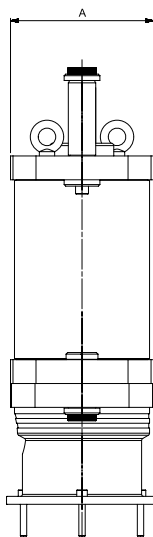

4	7,000 N·m UNIVERSAL TOOL TEST RIGS
50801	Universal 7,000 N·m ET, EBT, PT & Hydraulic Tool Test Rig (supplied with the 8 reaction plates on page 105 (excluding blank reaction plate) and ¾", 1" and 1½" sq. dr. adaptors)
50804	Universal 7,000 N·m Test Rig without Reaction Plates (supplied with ¾", 1" and 1½" sq. dr. adaptors)



TEST RIGS AND FIXTURES



Power Tool Test Rig with Reaction Plates (50800)



Universal Hydraulic Tool Test Rig with Reaction Plates (50801)



4 SPARES FOR 50800, 50801, 50803 & 50804

50800.29	2" AF Socket 1½" sq. dr.
50800.28	2" AF Socket 1" sq. dr.
50800.27	2" AF Socket ¾" sq. dr.



81041	Nut and bolt set for 7,000 N·m Power Tool Test Rigs
50548.4	Washer Stack Kit 100 - 7,000 N·m (Also for use with RD5000)

4 REACTION PLATES FOR USE WITH 50803 & 50804



81024	Suitable for ET/EBT/PTS/PTM 119, PT 4500 and PT 5500
-------	--



81025	Suitable for ET/EBT/PTS/PTM 92
-------	--------------------------------



81026	Suitable for ET/EBT/PTS/PTM 72
-------	--------------------------------



81027	Suitable for PTS/PTM 52
-------	-------------------------



81028	Suitable for PT 2700
-------	----------------------



81029	Suitable for PT 1, PT 1A and PT 2
-------	-----------------------------------



81030	Suitable for PT 5 and PT 6
-------	----------------------------



81031	Suitable for PT 7
-------	-------------------



81032	Blank Reaction Plate for Universal Test Rigs
-------	--

See page 107 for accessories for use with Hydraulic Tool Calibration Fixture.

NOTE: Reaction plate dimensions can be found by searching their part number on the Norbar website.



HYDRAULIC TOOL CALIBRATION FIXTURES

Norbar's Hydraulic Tool Calibration Fixture is a robust device that allows accurate testing of hydraulic torque wrenches. A system comprises of a Calibration Fixture and Transducer, also required is a torque measuring instrument and transducer cable.

- Bearing support for transducer gives improved accuracy
- Interchangeable stainless steel square and round reaction posts
- Hardened steel inserts to location reaction posts in two positions: suits most hydraulic wrenches
- Optimised material sections for robust but portable design
- For hexagon link wrenches, a wide range of hexagon to square adaptors are available

Hydraulic Tool Calibration Fixtures	107
Hexagon to Square Adaptors	109





HYDRAULIC TOOL CALIBRATION FIXTURES



Hydraulic Tool Calibration Fixture shown with Transducer
(Transducer not included)



Hexagon to Square Adaptor

4 CALIBRATION FIXTURES

80031	Hydraulic Calibration Fixture up to 7,000 N·m
80029	Hydraulic Calibration Fixture up to 50,000 N·m
80032	Hydraulic Calibration Fixture up to 80,000 N·m
81022	Reaction Bar for 80031
81023	Reaction Bar for 80029

4 TRANSDUCERS FOR USE WITH 80031 / 80030

50703.xxx*	250 - 2,500 N·m 1½" sq. dr. M/F
50704.xxx*	250 - 2,500 lbf·ft 1½" sq. dr. M/F
50599.xxx*	500 - 5,000 N·m 1½" sq. dr. M/F
50630.xxx*	500 - 5,000 lbf·ft 1½" sq. dr. M/F
50669.xxx*	700 - 7,000 N·m 1½" sq. dr. M/F

4 TRANSDUCERS FOR USE WITH 80029 / 80030

50776.xxx@	1,000 - 10,000 N·m 2½" sq. dr. M/F
50777.xxx@	1,000 - 10,000 lbf·ft 2½" sq. dr. M/F
50797.xxx@	2,500 - 25,000 N·m 2½" sq. dr. M/F
50781.xxx@	5,000 - 50,000 N·m 2½" sq. dr. M/F
50798.xxx@	25,000 lbf·ft 2½" sq. dr. M/F

4 TRANSDUCERS FOR USE WITH 80032

50782.xxx	6,000 - 60,000 lbf·ft 3½" sq. dr. M/F
50783.xxx	8,000 - 80,000 N·m 3½" sq. dr. M/F

Harsh Environment Transducers available on request.

4 DUAL CALIBRATION FIXTURE

80030	Dual Calibration Fixture
-------	--------------------------

Note: Houses 1 transducer up to 7,000 N·m and 1 transducer up to 50,000 N·m in a bench top plate.

9 ADDITIONAL CALIBRATION

The transducers shown include clockwise only calibration from 10% to 100% of rated capacity. For other calibration options, see below:

***ADDCALPOINTS.NEW**
Additional calibration steps below 10% of rated capacity to 2% for transducers up to 7,000 N·m (5,000 lbf·ft) when ordered with new unit

@SECCAL.CW
Secondary calibration in one direction on static transducers with 2½" square drives to extend the range below 10% of the rated capacity, when ordered with new unit

SECCAL.CW+CCW
Secondary calibration in two directions on static transducers with 2½" square drives to extend the range below 10% of the rated capacity, when ordered with new unit

9 HEXAGON TO SQUARE ADAPTORS - METRIC

29619.24	24 mm Hex to 1½" sq. dr. (Max 3,000 N·m)
29619.27	27 mm Hex to 1½" sq. dr. (Max 4,000 N·m)
29619.30	30 mm Hex to 1½" sq. dr. (Max 4,000 N·m)
29619.32	32 mm Hex to 1½" sq. dr. (Max 4,900 N·m)
29619.36	36 mm Hex to 1½" sq. dr. (Max 7,000 N·m)
29619.41	41 mm Hex to 1½" sq. dr. (Max 8,700 N·m)
29619.46	46 mm Hex to 1½" sq. dr. (Max 8,700 N·m)
29619.50	50 mm Hex to 1½" sq. dr. (Max 8,700 N·m)
29619.55	55 mm Hex to 1½" sq. dr. (Max 8,700 N·m)
29619.60	60 mm Hex to 1½" sq. dr. (Max 8,700 N·m)
29619.65	65 mm Hex to 1½" sq. dr. (Max 8,700 N·m)
29619.70	70 mm Hex to 1½" sq. dr. (Max 8,700 N·m)
29619.75	75 mm Hex to 1½" sq. dr. (Max 8,700 N·m)
29619.80	80 mm Hex to 1½" sq. dr. (Max 8,700 N·m)
29620.50	50 mm Hex to 2½" sq. dr. (Max 18,500 N·m)
29620.55	55 mm Hex to 2½" sq. dr. (Max 25,000 N·m)
29620.60	60 mm Hex to 2½" sq. dr. (Max 32,000 N·m)
29620.65	65 mm Hex to 2½" sq. dr. (Max 36,000 N·m)
29620.70	70 mm Hex to 2½" sq. dr. (Max 36,000 N·m)
29620.75	75 mm Hex to 2½" sq. dr. (Max 36,000 N·m)
29620.80	80 mm Hex to 2½" sq. dr. (Max 59,000 N·m)
29620.85	85 mm Hex to 2½" sq. dr. (Max 59,000 N·m)
29620.90	90 mm Hex to 2½" sq. dr. (Max 59,000 N·m)
29620.95	95 mm Hex to 2½" sq. dr. (Max 59,000 N·m)
29620.100	100 mm Hex to 2½" sq. dr. (Max 52,000 N·m)
29620.105	105 mm Hex to 2½" sq. dr. (Max 52,000 N·m)
29620.110	110 mm Hex to 2½" sq. dr. (Max 52,000 N·m)
29620.115	115 mm Hex to 2½" sq. dr. (Max 52,000 N·m)
29620.130	130 mm Hex to 2½" sq. dr. (Max 52,000 N·m)



Dual Calibration Fixture
Part No. 80030
(Transducers not included)



HYDRAULIC TOOL CALIBRATION FIXTURES



Model	Hydraulic Calibration Fixture up to 7,000 N-m	Hydraulic Calibration Fixture up to 50,000 N-m	Hydraulic Calibration Fixture up to 80,000 N-m
Part Number	80031	80029	80032
Dimensions (mm)	A	202	292
	B	240	325
	C	175	125
	D	180	150
	E	115	250
	F	115	N/A
	G	180	250
Weight (kg)	TBC	TBC	TBC

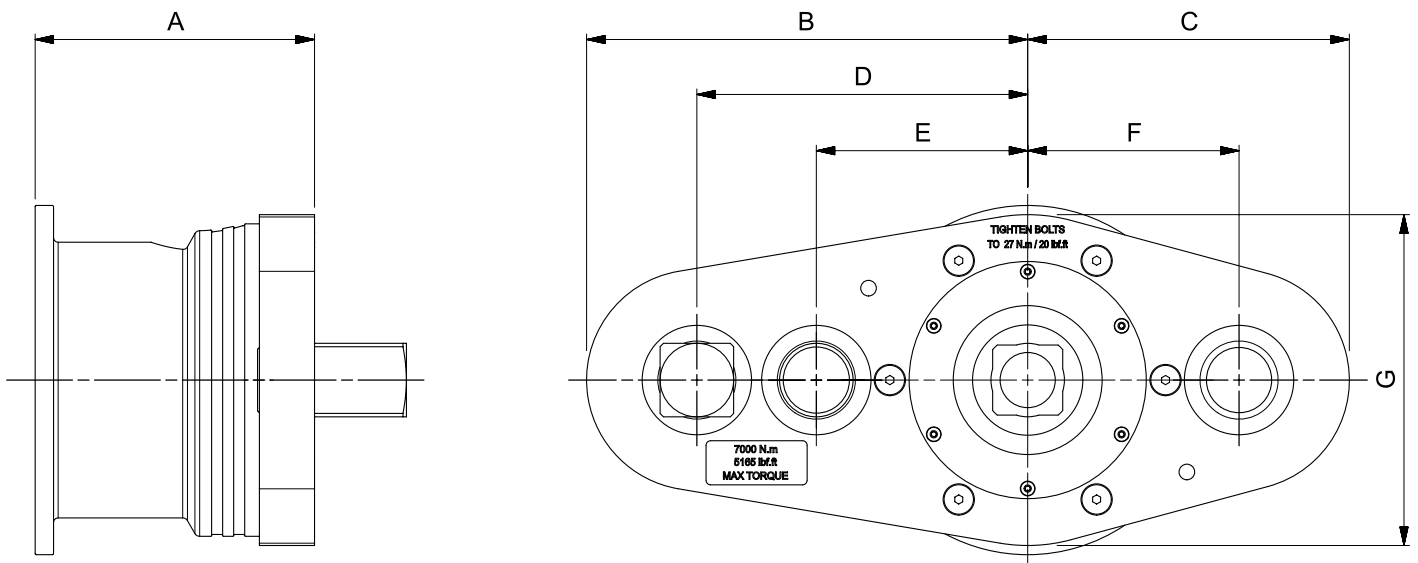

Model	Dual Calibration Fixture	
Part Number	80030	
Dimensions (mm)	A	710
	B	193
	C	250
	D	142
	E	150
	F	380
	G	105
Weight (kg)	140.0	

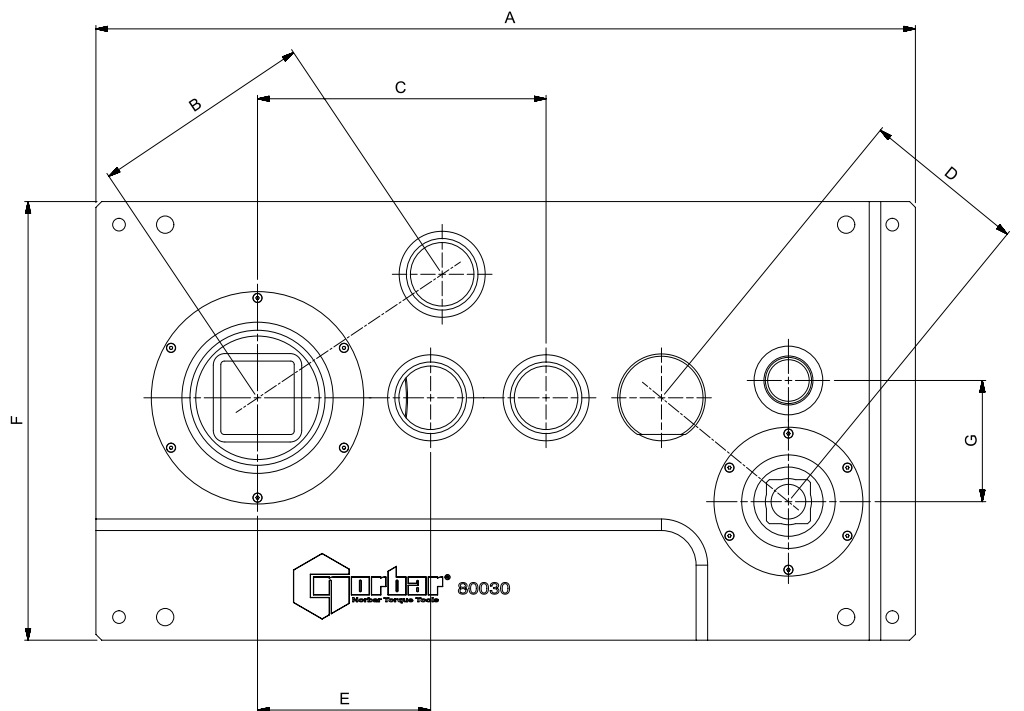



HEXAGON TO SQUARE ADAPTORS



Fixture shown with Hydraulic Torque Wrench

9	HEXAGON TO SQUARE ADAPTORS - IMPERIAL
29623.I20	1¼" Hex to 1½" sq. dr. (Max 4,900 N·m)
29623.I23	1⅞" Hex to 1½" sq. dr. (Max 7,000 N·m)
29623.I26	1⅝" Hex to 1½" sq. dr. (Max 8,700 N·m)
29623.I29	1⅜" Hex to 1½" sq. dr. (Max 8,700 N·m)
29623.I32	2" Hex to 1½" sq. dr. (Max 8,700 N·m)
29623.I35	2⅞" Hex to 1½" sq. dr. (Max 8,700 N·m)
29623.I38	2⅝" Hex to 1½" sq. dr. (Max 8,700 N·m)
29623.I41	2⅞" Hex to 1½" sq. dr. (Max 8,700 N·m)
29624.I35	2⅞" Hex to 2½" sq. dr. (Max 25,000 N·m)
29624.I38	2⅞" Hex to 2½" sq. dr. (Max 32,000 N·m)
29624.I41	2⅞" Hex to 2½" sq. dr. (Max 36,000 N·m)
29624.I44	2¾" Hex to 2½" sq. dr. (Max 36,000 N·m)
29624.I47	2⅝" Hex to 2½" sq. dr. (Max 36,000 N·m)
29624.I50	3⅞" Hex to 2½" sq. dr. (Max 59,000 N·m)
29624.I56	3½" Hex to 2½" sq. dr. (Max 59,000 N·m)
29624.I62	3⅞" Hex to 2½" sq. dr. (Max 52,000 N·m)

9	HEXAGON TO SQUARE ADAPTORS - IMPERIAL
29624.I68	4¼" Hex to 2½" sq. dr. (Max 52,000 N·m)
29624.I74	4⅝" Hex to 2½" sq. dr. (Max 52,000 N·m)
29624.I80	5" Hex to 2½" sq. dr. (Max 52,000 N·m)
29624.I86	5⅝" Hex to 2½" sq. dr. (Max 52,000 N·m)
29624.I98	6⅞" Hex to 2½" sq. dr. (Max 52,000 N·m)

9	SLEEVE ADAPTORS
86034.4	Adaptor 1½" Male sq. dr. ¾" Female sq.
21214	Adaptor 1½" Male sq. dr. 1" Female sq.
290100	Adaptor 2½" Male sq. dr. ¾" Female sq.
290101	Adaptor 2½" Male sq. dr. 1" Female sq.
29617	Adaptor 2½" Male sq. dr. 1½" Female sq.
290103	Adaptor 3½" Male sq. dr. 1½" Female sq.
29618	Adaptor 3½" Male sq. dr. 2½" Female sq.

Special 'Engineer to Order' hexagon and square adaptors available on request.



Sleeve Adaptors



TOOL CONTROLLERS

Norbar's Tool Controllers are used in a range of industries and applications where a high degree of tool control, automation or data gathering is required. In addition to the input of torque data, the controller can simultaneously take data from other sensors, such as angle or pressure, and the various inputs analysed together. It is possible, for example, to compare the inputs from multiple torque transducers or torque vs. angle or torque vs. pressure. In this way, Norbar Torque Controllers have been utilised in a diverse range of applications with typical examples being valve testing (torque vs. angle vs. time), automated hydraulic torque wrench testing (torque vs. pressure) and multi-spindle tool control. Logic within the Controller can be used to interface with other parts of a manufacturing or testing process to achieve go / no-go control for example, a process can be halted until certain measured parameters are met. Norbar's latest controller, illustrated below, uses a colour touch screen user interface for the easy input of details such as: test piece identifiers - type and serial number, operator name and specific targets to meet.

Examples of Norbar Tool Controllers are shown on page 111 but, in fact, these products are highly customised and will be engineered and programmed for our customers' specific requirements. For more details please visit the Engineer to Order section of the Norbar website at: www.norbar.com/Services/Engineer-to-Order or contact your Norbar distributor to discuss your requirements.

Tool Controllers

111





TOOL CONTROLLERS

The Tool Controller shut-off system is supplied in a wall box for 'External Control' versions of the Norbar PTM series of tools. This can give a much greater range of functionality than is possible on the 'Internal Control' version of the tool.



11 TOOL CONTROLLER (TTT based)

60244 Shut-off system in wall box
Tool Controllers are supplied without leads

61127.600 Lead for PTM Series Tool

61126.600 Transducer Lead for PT Series Tool

61128.600 Solenoid Lead for PT Series Tool (for single valve)

Other lead lengths can be ordered at an additional cost. Both 61126.600 and 61128.600 are required to control a PT Series tool with a tool controller.

11 TRANSDUCER LEADS FOR TOOL CONTROLLERS

61135.600 Transducer Lead for PTM-EC and Angle Series Tools, 6 m

61135.1000 Transducer Lead for PTM-EC and Angle Series Tools, 10 m

60308.400 PRO-LOG, TST, TTT, T-Box XL & T-Box 2 to Torque & Angle Annular Transducers

60308.600 PRO-LOG, TST, TTT, T-Box XL & T-Box 2 to Torque & Angle Annular Transducers

60308.1000 PRO-LOG, TST & TTT to Torque & Angle Annular Transducers

The models above are a sample of the controllers that Norbar produce. Please contact Norbar for your special requirements.

Tool Controller for Valve Testing

Tool controller for PneuTorque® remote tools fitted with annular torque & angle transducer and solenoid operated valve assemblies.

- 10" touchscreen HMI & PLC housed in a painted steel enclosure for indoor / workshop use
- Data entry fields for test valve details, operator, time, date, torque limits & angle / turns limits
- Forward / reverse cycling to user programmable number of cycles, variable up to 32,000°
- One torque transducer port, for 'LOGA' or 'LOG' connection
- One twin solenoid port for connection to valve assembly
- One hand pendant input port
- Two proximity limit switch ports (for use where angle is not measured at the transducer)
- One customer pressure sensor port, (2mV/V), for data recording (not tool shut-off)
- One RS232 + one USB data output ports
- Real time torque & angle or torque & turns data streaming
- Test data capture and output in CSV format onto external USB drive, for the generation of customer test reports & graphs
- Emergency stop button and torque overload limit function



Tool Controller for Hydraulic Tool Calibration

Hydraulic wrench calibration controls kit allows the ability to generate data for download to a calibration certificate template on customer's PC. This controller is capable of taking simultaneous inputs from a calibrated torque transducer and pressure sensor at 50 Bar intervals. Data is stored, and matched torque vs pressure readings are output, along with customer pre-loaded test information to the customer's PC for calibration certificate generation.



Tool Controller with Hand Pendant from Valve Testing Controls Kit for use with AC servo drive or pneumatic drive tools

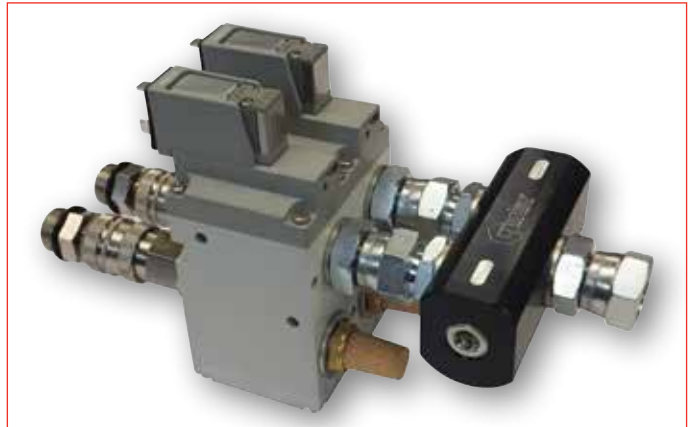

Example of Remote 108 Operating Valve Assembly fitted to a 108 Remote Motor Part No. 60309

This assembly includes two 3 way shut-off valves Part No. 28943

8 3 WAY SHUT-OFF VALVE

28943 3 Way Shut-off Valve 10 BAR Maximum Air Pressure

8 TWIN SOLENOID VALVE ASSEMBLY

60309 Twin Solenoid Valve Assembly for 108 Remote Tools

60310 Twin Solenoid Valve Assembly for 72 Remote Tools

60298.600* Solenoid Lead for twin valve assembly, 6 m

60298.1000* Solenoid Lead for twin valve assembly, 10 m

* For use with special tool controllers.



HARSH ENVIRONMENT

Norbar has worked closely with the oil and gas industry to produce a range of torque instruments and transducers suitable for use in the harshest environments such as ship decks, oil rigs and refineries. Norbar uses a variety of corrosion resistant materials, high specification connectors and sealing techniques meaning that products in our HE range can be used in such environments without impairing their performance or life span. Although originally designed to meet the needs of the oil and gas industry, Norbar’s HE range is the ideal choice whenever it is necessary to apply or measure torque outdoors in potentially wet or dusty conditions.

Harsh Environment Instrument	113
TTL-HE Instrument And Transducer Kits	113
Harsh Environment Transducers	114
Intervention Tool Verification Kits	115
Intervention Tool Test Pots	116
Multipliers For Subsea	116
Engineer To Order	117





HARSH ENVIRONMENT INSTRUMENT



TTL-HE is a portable torque measuring instrument designed for use in harsh environments. The TTL-HE operating on battery power with one of the 'HE' range of transducers connected, has an ingress protection rating of IP65/IP67. Typical operating environments are where high humidity, water or salt water spray and dust may be an issue. Features include; 10 measurement modes, 13 units of torque (with additional user units feature), 12 pairs of limits and text displayed in 11 languages.

- IP65/67 rated
- Bi-directional calibration
- Battery power use in harsh environments (mains supply for charging)
- All features are in common with TST and TTT instruments
- Supplied in IP67 rated carry case
- 5 digit resolution for all Norbar transducers
- 240 x 64 pixel dot matrix display with update rate of twice per second
- Please contact Norbar for full details of available transducers

4 HARSH ENVIRONMENT RANGE

43217 TTL-HE Instrument (inc. IP67 rated carry case)
Supplied with clockwise and counter-clockwise calibration

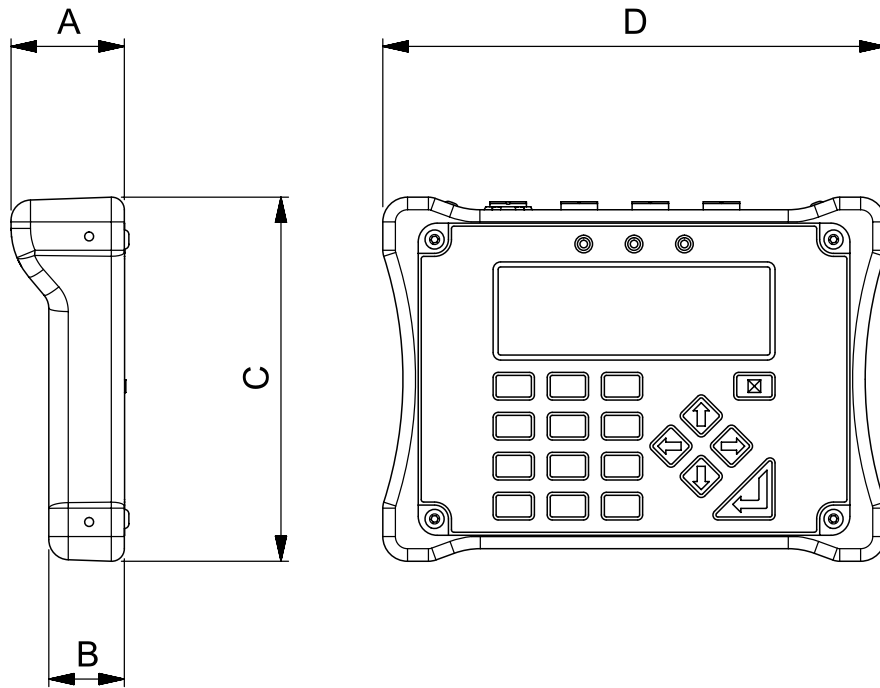

Model	TTL-HE	
Part Number	43217	
Dimensions (mm)	A	45
	B	30
	C	145
	D	200
Weight (kg)	4.9	

TTL-HE INSTRUMENT AND TRANSDUCER KITS



4 TTL-HE INSTRUMENT AND TRANSDUCER KITS

60287.LOG	5,000 N·m M/M TTL-HE Kit, inc. Lead	(Class 4)
60295.LOG	10,000 N·m M/M TTL-HE Kit, inc. Lead	(Class 5)
60296.LOG	15,000 N·m M/M TTL-HE Kit, inc. Lead	(Class 6)
60289.LOG	40,000 N·m M/M TTL-HE Kit, inc. Lead	(Class 7)

Note: Kits for use with Intervention Tool Test Pots



HARSH ENVIRONMENT TRANSDUCERS



The accuracy and quality of the Norbar torque transducers has made them the first choice of many calibration laboratories throughout the world. The Harsh Environment range of transducers has been specifically designed for use with the Norbar TTL-HE instrument.

- Class 1 accuracy over the 'Primary' classification range (±0.5% of reading from 20 to 100% of full scale)
- IP65/IP67 rated
- Stainless steel design with Smart intelligence
- Bi-direction calibration as standard



4	STATIC TRANSDUCERS
50787.xxx	300 - 3,000 N·m 1½" M/F sq. dr.
50751.xxx*	300 - 3,000 N·m 1½" M/M sq. dr.
50705.xxx	500 - 5,000 N·m 1½" M/F sq. dr.
50729.LOG	500 - 5,000 N·m 1½" M/M sq. dr.
50706.xxx	500 - 5,000 lbf-ft 1½" M/F sq. dr.
50728.xxx	1,000 - 10,000 N·m 2½" M/F sq. dr.
50788.xxx	1,000 - 10,000 N·m 2½" M/ 2" M sq. dr.
50789.xxx	1,500 - 15,000 N·m 2½" M/ 2½" M sq. dr.
50726.xxx	2,500 - 25,000 N·m 3½" M/M sq. dr.
50727.xxx	4,000 - 40,000 N·m 3½" M/M sq. dr.
50743.xxx*	10,000 - 100,000 lbf-ft 3½" M/M sq. dr.

* Suitable for use in Hydraulic Test Pots.

* UKAS accredited calibration up to 80,000 lbf-ft. A non-accredited value at 100,000 lbf-ft is extrapolated and provided for reference only. Static Transducers 3,000 N·m and above supplied in carry case.

Annular Transducers

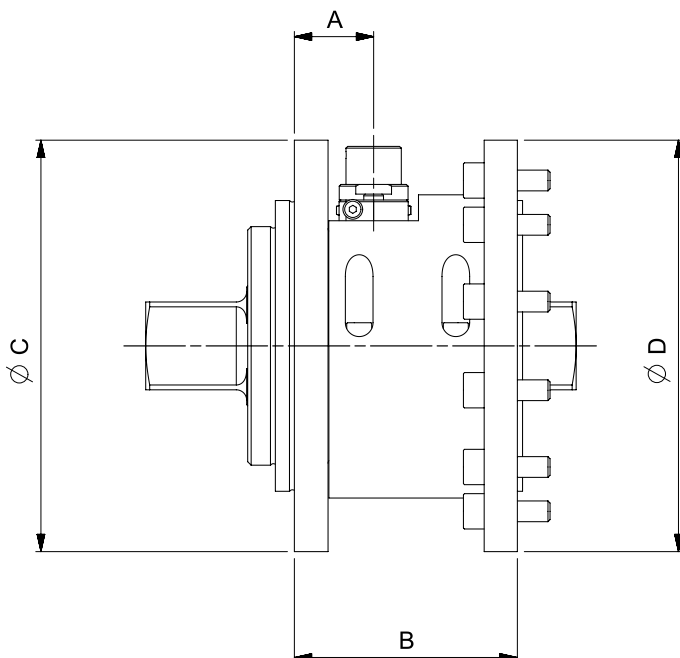

4	ANNULAR TRANSDUCERS
50767.xxx	100 - 1,000 N·m including drive shaft
50745.xxx	350 - 3,500 N·m including drive shaft
50725.xxx	1,000 - 10,000 N·m no drive shaft

Other transducers available upon request.

All above HE transducers supplied with clockwise and counter-clockwise calibration.

Designed for use with the Harsh Environment Instrument range (TTL-HE) of products

4	INSTRUMENTATION LEADS
60245.200	TTL-HE to HE Transducer
60250.200	TTL-HE to Norbar Static & Annular Transducers
60263.200	TTL-HE to Rotary Transducers
60266.200	HE Transducer to TTT, TST and T-Box 2
60261.200	Serial Data Lead for TTL-HE

Other lengths can be ordered at an additional cost.

Note: The system should be calibrated with the increased length lead, as calibration may be affected.

Note: The maximum permissible cable length 15 m for Transducer Leads, 7 m if using 60266 with a T-Box XL™. Contact Norbar for further details.

Model	1,000 N·m	3,500 N·m	10,000 N·m
Part Number	50767.xxx	50745.xxx	50725.xxx
Dimensions (mm)	A	22	39
	B	60	77
	∅C	108	178
	∅D	108	184
Weight (kg)	3.4	4.0	5.8



HARSH ENVIRONMENT TRANSDUCERS



Static Transducers - Male to Male (M/M) Square Drives

Model	3,000 N·m 5,000 N·m	10,000 N·m	15,000 N·m	25,000 N·m 40,000 N·m 100,000 lbf·ft
Part Number	50751.xxx 50729.xxx	50788.xxx	50789.xxx	50726.xxx 50727.xxx 50743.xxx
Dimensions (mm)	ØA	95	110	164
	B	68	75	103
	C	168	200	225
	D	38	57	57
	E	84	101	101
	F	38	57	58
Weight (kg)	3.4 (3,000 N·m) 5.0 (5,000 N·m)	11.4	11.4	21.5 (25,000 N·m) 22.0 (40,000 N·m) 25.0 (100,000 lbf·ft)

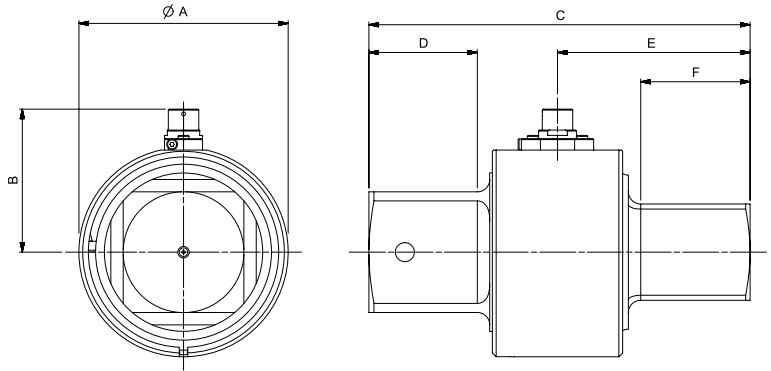

Static Transducers - Male to Female (M/F) Square Drives

Model	3,000 N·m 5,000 N·m 5,000 lbf·ft	10,000 N·m	
Part Number	50787.xxx 50705.xxx 50706.xxx	50728.xxx	
Dimensions (mm)	ØA	95	110
	B	68	83
	C	160	189
	D	41	59
	E	84	100
	F	38	57
Weight (kg)	5.0	9.1	

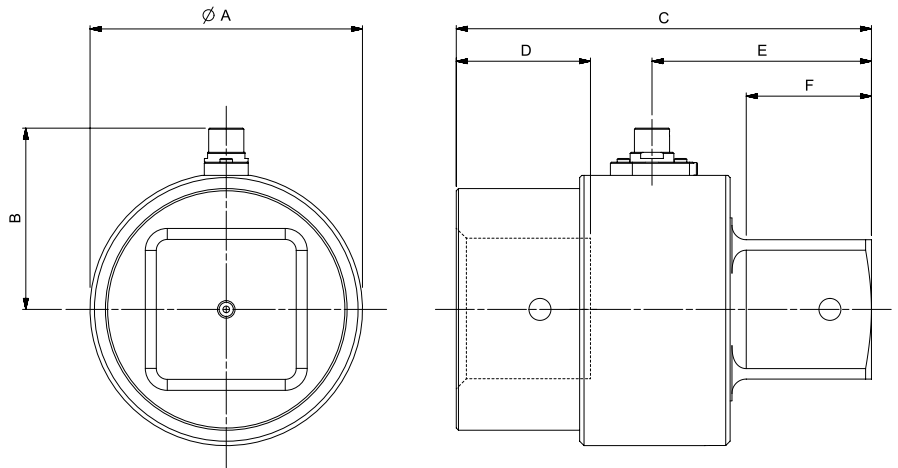

INTERVENTION TOOL VERIFICATION KITS



4	INTERVENTION TOOL TORQUE VERIFICATION KIT
60278.xxx	3,000 N·m ISO 13628 Class 4 Intervention Tool Torque Verification Kit
60281.xxx	10,000 N·m ISO 13628 Class 5 Intervention Tool Torque Verification Kit
60282.xxx	15,000 N·m ISO 13628 Class 6 Intervention Tool Torque Verification Kit
60279.xxx	25,000 N·m API 17D Class 7 (short) Intervention Tool Test Kit
60280.xxx	40,000 N·m API 17D Class 7 (short) Intervention Tool Test Kit

Other test pots and Torque Verification Kits are available for standard and non-standard API Intervention tool test and verification. Please contact Norbar.



INTERVENTION TOOL TEST POTS

These reaction pots allow for the accurate testing of API rotary intervention tools.

- Conform to ISO 13628-8:2002 and API 17D
- Customer specific solutions also available
- Lightweight all aluminium construction
- Incorporated lifting handles
- Eye bolts provided on larger units



Model	Class 4	Class 5	Class 6	Class 7
Part Number	80019	80024	80025	80020
Dimensions (mm)	A	372	403	428
	B	215	246	326
Weight (kg)	17.5	22.0	51.0	48.0

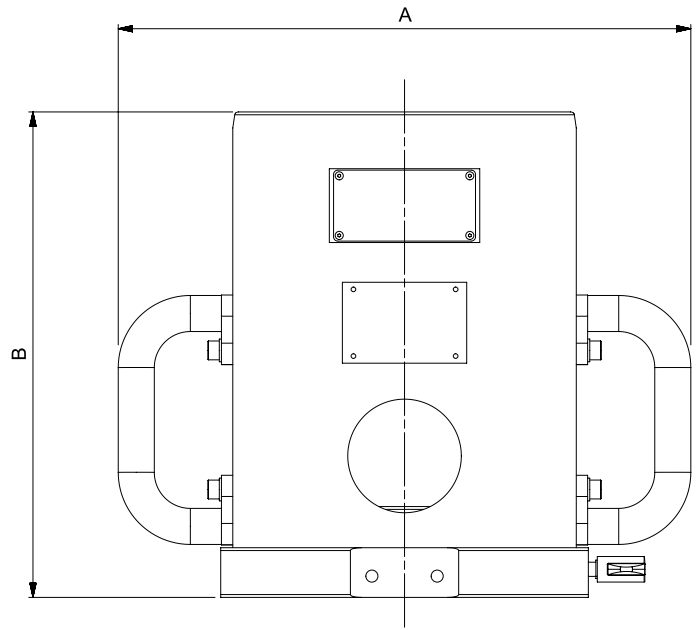

4	INTERVENTION TOOL TEST POTS
80019	ISO 13628-8:2002 Class 4 Intervention Tool Test Pot
80024	ISO 13628-8:2002 Class 5 Intervention Tool Test Pot
80025	ISO 13628-8:2002 Class 6 Intervention Tool Test Pot
80020	API 17D Class 7 Intervention Tool Test Pot
81018	Deck Mount Kit for API Verification Pot

MULTIPLIERS FOR SUBSEA



4	MULTIPLIERS FOR INTEGRATION INTO SUBSEA INTERVENTION TOOLS
77331	HT5 5:1 for Subsea Intervention Tools
77301	HT5 5:1 for Subsea Splined Output

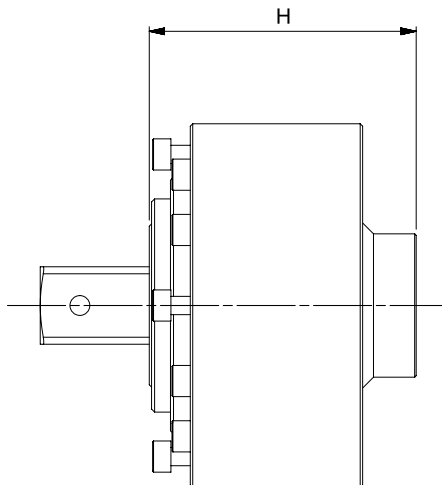
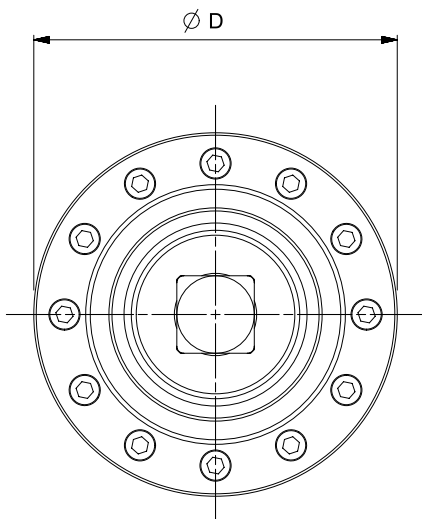

Model	HT5 5:1 Subsea	
Part Number	77331 77301	
Dimensions (mm)	D	119
	H	88
Weight (kg)	TBC	



ENGINEER TO ORDER

Norbar's wide range of standard equipment may not meet your exact requirements as there are applications when something special is required.

As an ISO 9001 accredited company, Norbar will undertake the design and manufacture of special equipment against agreed customer specifications.

These projects range from modified torque wrench end fittings to complete torque and angle control of valve testing kits. Relevant safety directives are applied where appropriate, leading to well engineered reliable products that are designed to make tasks safer and easier.

For more information on Norbar's Engineer to Order service please e-mail your enquiry to technical@norbar.com or visit the Engineer to Order section of the Norbar website at: www.norbar.com/Services/Engineer-to-Order



Model 60 'P' Type torque wrench, HandTorque® HT-52/22 and a 5 gear Offset Gearbox Kit for tightening Pintle Bolts



Subsea 63,000 N·m pipe clamp tool under test



HT 7 torque multiplier & No.7 annular transducer with special input drive & reaction



Valve testing controls kit for use with AC servo drive or pneumatic drive tools



Class 4 to 20,000 N·m subsea torque multiplier & verification kit, for pipe clamp actuation



Ultrasonic measurement provides a very precise method of determining the elongation of a fastener due to tightening. This elongation is proportional to the load force generated by the fastener.



The basic principle behind this method of tension control is similar to sonar. The ultrasonic measurement of bolt tension is achieved by introducing a sonic pulse at one end of the fastener and accurately measuring the time of flight (TOF) required for the echo to return from the opposite end. Using material constants, the USM-3 converts this TOF into an 'acoustic length' of the fastener, providing a baseline from which future measurements will be made. When the fastener is tightened: the TOF increases and the USM-3 will again utilise material constants to eliminate the effects of stress and temperature variations on sound velocity, providing an accurate elongation or load measurement.

The USM-3 uses state of the art hardware and digital signal processing to achieve these measurements with maximum automation, minimizing the need for operator interpretation. Once measurements have been recorded to the USM-3 internal memory, the included SonicBolt software will transfer the data to a computer for backup of files, creation of project reports, and conversion of data to Excel format for further analysis. In addition, the analogue signal output can be used to automatically shut-off powered torque and tensioning tools based on elongation or load, in even the most demanding applications.

Model	USM-3	
Part Number	40334	
Dimensions (mm)	A	180
	B	53
	C	240
Weight (kg)	2.3	

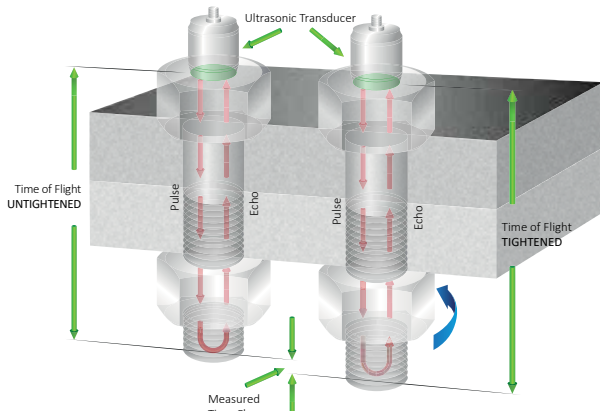

9	USM-3 ULTRASONIC STRESS METER
40334	USM-3 instrument with AC adaptor, nylon case, storage case, transducer cable, RS-232 cable, couplant and manual

Magnetic Transducers - This standard style is used with ferrous materials, and consists of a rare earth magnet surrounding the piezo electric transducer.

9	TRANSDUCERS
56016	3/16" 5 MHz Magnetic Transducer
56017	3/16" 7.5 MHz Magnetic Transducer
56018	3/16" 10 MHz Magnetic Transducer
56009	1/4" 5 MHz Magnetic Transducer
56019	1/4" 10 MHz Magnetic Transducer
56011	1/2" 2.25 MHz Magnetic Transducer
56010	1/2" 5 MHz Magnetic Transducer
56020	3/4" 1 MHz Magnetic Transducer
56013	3/4" 2.25 MHz Magnetic Transducer
56012	3/4" 5 MHz Magnetic Transducer
56021	Glue on, 3 mm square, 7.5 MHz, pack of 100

Operating temperature limit for transducers is 55°C. Contact Norbar for details of high temperature transducers with a temperature limit of 175°C.

9	TRANSDUCER LEADS
60235	Transducer Lead 10' (approx 3 m)
60236	Transducer Lead 20' (approx 6 m)
Q2408	Probe for glue on Ultrasonic TD's

9	SPARES & ACCESSORIES
61112	Ultrasonic Couplant Bottle 4 oz (approx 0.12 litres)
61116	Serial Lead 6' DB9 M to DB9 F
61117	Length Bar Set 3" & 6" with certificate
60271	Digital Thermometer (Accuracy ±0.5°C / ±1°F)

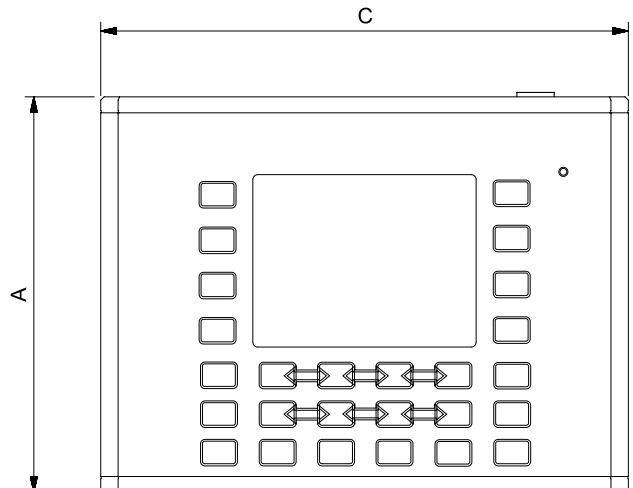
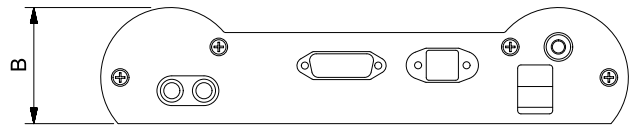

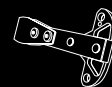

CALIBRATION BEAMS & WEIGHTS

Designed to remove potential sources of measurement error, these beams can be used to calibrate Norbar torque transducers, and torque transducers from other manufacturers (where design permits), as well as mechanical test devices. A UKAS accredited calibration certificate for the measurement of the torque radius is provided with each beam. Note: A temperature controlled environment is essential for use of these beams. The selection of weights will be influenced by gravitational constant and air buoyancy values at the proposed laboratory site.

Principles of Operation	121
Calibration Beams & Weights	122



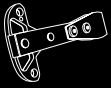

CALIBRATION BEAMS & WEIGHTS - PRINCIPLES OF OPERATION

Norbar's test beams are designed for the static calibration of torque transducers. They are ideally suited to Norbar's transducers, but can be employed on other manufacturer's equipment.

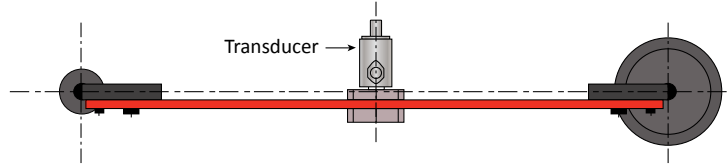

Torque is generated by the application of a known force at a known radius from the centre of rotation of the torque transducer.

The beams are designed with square drives machined to the top limit of ISO 2725. This minimises any play between the beam and the transducer. However, a combination of square drive tolerances, misalignment of fittings and elastic rotation of the transducer shaft inevitably cause the beam to rotate from the horizontal under load.

Norbar's radius ended beams are designed with a $\pm 8^\circ$ usable arc within which the calibration accuracy is unaffected.

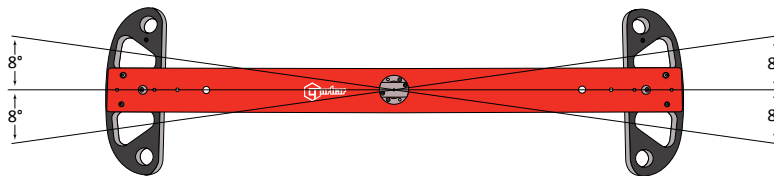
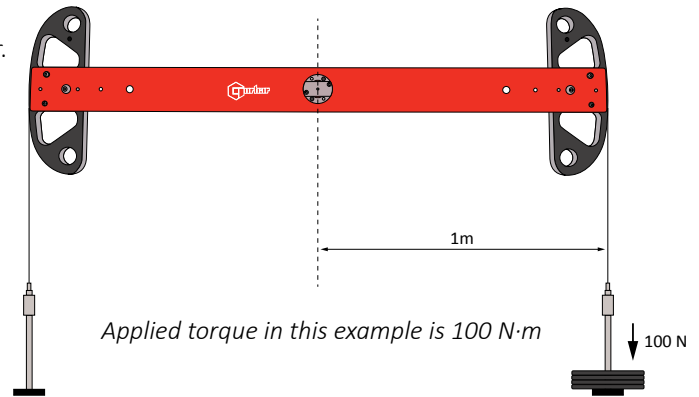

Additionally, the beams are designed to apply load on a vertical plane which cuts through the square drive inside the transducer. This minimises bending moments on the transducer and for safe operation, ensures that the beam will not fall out of the transducer.

Gravitational Effects

It is very important that the gravitational value for the laboratory is established. The effect of not doing this could be a variation in the force produced by the weight of perhaps 0.5% of reading.

It is therefore strongly recommended that you establish the local value of gravity (g) for your Laboratory and use weights that have been calibrated at that gravitational constant.

Norbar will supply weights calibrated to gravitational constants specified by the customer. However, if the customer does not specify a value for 'g' they will have been calibrated at an estimated gravitational constant for the customers' location.

Buoyancy Effects

The Norbar system uses calibrated weights to generate a downwards force.

This means that Archimedes' principle applies, ie. air pressure under the weights causes an upwards force. This reduces the effective force generated by the weights and therefore the mass must be increased to allow for this.

Under standard conditions (i.e. air density 1.2 kg/m³ and 20° centigrade and working in conventional mass terms) the increase required is by a factor of 0.015%.

Weights purchased from Norbar will already have this factor taken into account.

Weights that are calibrated to standard procedures do not have this factor taken into account because the air buoyancy affects both sides of the mass balance and can be ignored. It is important that weights used for torque transducer calibration are adjusted for air buoyancy.

It should also be noted that the double ended beam design employed by Norbar means that each half of the beam is balanced with regard to buoyancy of the beam. This is a significant advantage over single-arm counterbalanced systems.

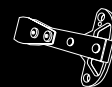

CALIBRATION BEAMS & WEIGHTS



9	METRIC - NEWTON METRE SIZES	
21400	100 mm	Torque Radius Disc (100 mm)
21429	0.5 - 60 N·m	Radius Ended Beam (0.25 m)
21421	5 - 150 N·m	Radius Ended Beam (0.5 m)
21427	50 - 500 N·m	Radius Ended Beam (0.5 m)
21428	10 - 1,500 N·m	Radius Ended Beam (1.0 m)
21842	500 - 5,000 N·m	Free Standing Beam

With the exception of 21842 all calibration beams are supplied in a protective wooden box. A UKAS accredited calibration certificate for the measurement of the torque radius is provided with each beam.

9	WEIGHTS FOR THE DISC 21400	
21452.NAM	Brass weight set to give 0.5 N·m	
21450.NAM	Brass weight set to give 1.0 N·m	
21479.NAM	Brass weight set to give 2.5 N·m	

9	WEIGHTS FOR THE BEAM 21429	
21476.NAM	Cast iron weight set to give 5 N·m	
21454.NAM	Cast iron weight set to give 10 N·m	
21458.NAM	Cast iron weight set to give 50 N·m	
Q2343.NAM	Cast iron weight set to give 60 N·m	

9	WEIGHTS FOR THE BEAM 21421	
21477.NAM	Cast iron weight set to give 50 N·m	
21458.NAM	Cast iron weight set to give 100 N·m	

9	WEIGHTS FOR THE BEAM 21427/21428	
21459.NAM	Cast iron weight set to give 250/500 N·m	
21460.NAM	Cast iron weight set to give 500/1,000 N·m	
21483.NAM	Cast iron weight set to give 500/1,000 & 1,500 N·m	

e.g. set 21459.NAM will give 250 N·m on a 21427 beam and 500 N·m on a 21428.

9	WEIGHTS FOR THE BEAM 21842	
21469.NAM	Cast iron weight set to give 5,000 N·m	

All weight sets come with traceable UKAS accredited calibration certificate. This requires the customer to provide the value for 'g' (local gravity) for the intended place of use when ordering.



Model	100 mm Disc	0.25 m Beam	0.5 m Beam	0.5 m Beam	1 m Beam	Free Standing Beam	
Part Number	21400	21429	21421	21427	21428	21842	
Dimensions (mm)	A	100	250	500	500	1,000	* 1,524
	B max.	295	650	755	1,015	1,015	1,070
Weight (kg)	0.5	1.2	5.0	17.0	25.0	270.0	

* A max.

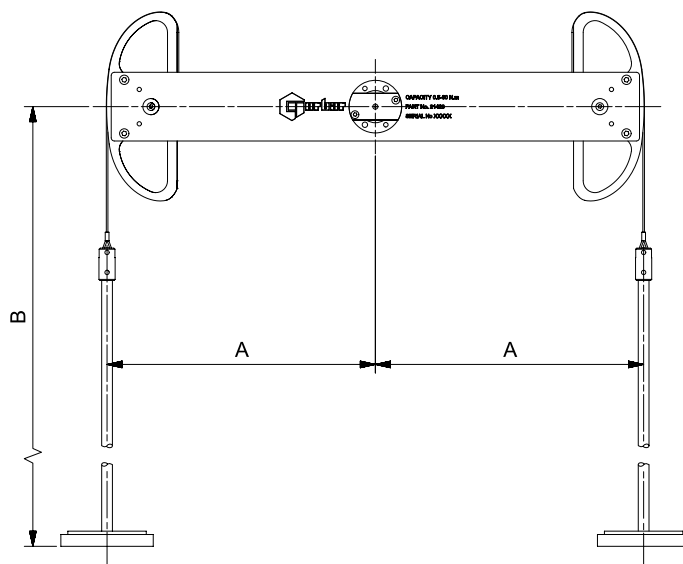



CALIBRATION BEAMS & WEIGHTS



9 IMPERIAL - POUNDS FEET SIZES		
21400	100 mm	Torque Radius Disc (100 mm)
21430	10 - 500 lbf-in	Radius Ended Beam (10")
21424	10 - 100 lbf-ft	Radius Ended Beam (12")
21425	50 - 500 lbf-ft	Radius Ended Beam (24")
21426	100 - 1,000 lbf-ft	Radius Ended Beam (48")
21842	500 - 5,000 lbf-ft	Free Standing Beam

With the exception of 21842 all calibration beams are supplied in a protective wooden box. A UKAS accredited calibration certificate for the measurement of the torque radius is provided with each beam.

9 WEIGHTS FOR THE DISC 21400	
21455.NAM	Brass weight set to give 50 ozf-in
21453.NAM	Brass weight set to give 100 ozf-in
21451.NAM	Brass weight set to give 160 ozf-in

9 WEIGHTS FOR THE BEAM 21430	
21465.NAM	Cast iron weight set to give 100 lbf-in
21466.NAM	Cast iron weight set to give 500 lbf-in

9 WEIGHTS FOR THE BEAM 21424	
21467.NAM	Cast iron weight set to give 100 lbf-ft

9 WEIGHTS FOR THE BEAM 21425	
21468.NAM	Cast iron weight set to give 500 lbf-ft

9 WEIGHTS FOR THE BEAM 21426	
21468.NAM	Cast iron weight set to give 1,000 lbf-ft

9 WEIGHTS FOR THE BEAM 21842	
21469.NAM	Cast iron weight set to give 5,000 lbf-ft

All weight sets come with a traceable UKAS accredited calibration certificate. This requires the customer to provide the value for 'g' (local gravity) for the intended place of use when ordering.

Model	100 mm Disc	10" Beam	12" Beam	24" Beam	48" Beam	Free Standing Beam
Part Number	21400	21430	21424	21425	21426	21842
Dimensions (mm)	A	100	254	305	610	* 1,524
	B max.	295	650	690	965	1,015
Weight (kg)	0.5	1.2	3.7	17.3	26.4	270.0

* A max.

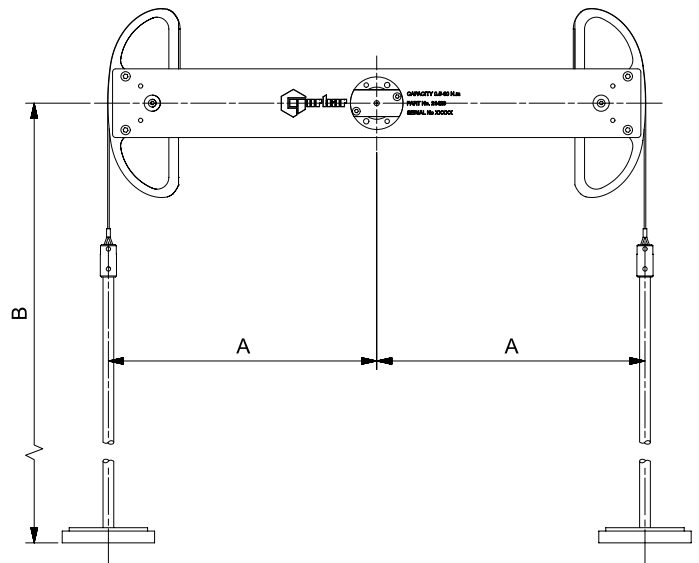

9 ANCILLARY PRODUCTS FOR CALIBRATION BEAMS	
80000	Pedestal for mounting calibration equipment
80005	Adjustable Angle Attachment

9 CALIBRATION FIXTURES	
J2239	Transducer calibration fixture 1/4" sq
J2237	Transducer calibration fixture 3/8" sq
J2244	Transducer calibration fixture 1/2" sq
J2240	Transducer calibration fixture 3/4" sq
J2241	Transducer calibration fixture 1" sq
J3305	3° Angled Plate for use with calibration fixtures

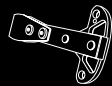

CALIBRATION CERTIFICATES



As a UKAS accredited calibration Laboratory No. 0256, Norbar is required to calibrate torque measuring devices that are within the laboratory's scope, in accordance with BS 7882:2017. See the 'UKAS Schedule of Accreditation' on the 'Calibration Services' page of our website, www.norbar.com.

Norbar can provide a comprehensive range of calibrations including increasing and decreasing torques; clockwise and counter-clockwise; in either SI or English torque units, or in mV/V or Volts.

The sections below summarise the main features of BS 7882:2017, but purchase and careful study of the standard is advised for those who wish to have more detailed information.

Procedure

- The 'device' is defined as all parts of a system, e.g. Display, Transducer cable and Transducer. Transducer cables will therefore be serial numbered if they are separate items.
- The output of the device is defined as 'deflection'.
- It is preferable to calibrate all parts of a system together. If a transducer is sent for calibration without its normal display unit, an equivalent calibrated display held in the laboratory will be used. The normal display must also be in a calibrated state or the certification for the transducer is invalidated.
- Norbar is currently the only laboratory accredited by UKAS for the calibration of Electrical Torque Measuring Indicators.
- Before any calibration or recalibration the torque measuring device is preloaded three times in succession to the maximum applied torque of the device. Each preload is maintained for a minimum of 30 seconds to exercise the device and stabilise it in the calibration fixture.
- The device is calibrated with at least five approximately equal steps from 20% to 100% of maximum torque. Lower values are allowed as long as they meet certain criteria for resolution.
- For Classes 0.05 and 0.1, it is mandatory to calibrate the torque measuring device in four different mounting positions each rotated 90° about the measurement axis. For all other classes the device is calibrated at a minimum of two different mounting positions at least 90° apart.
- Two series of readings are taken, and the device is then disturbed, generally by being disconnected from the calibration fixture and rotated through 90°. The device is then preloaded once to full scale. A third series of readings are then taken. This process is repeated until readings have been recorded in all required orientations.
- If reversibility is required, a single series of decreasing torques are applied at the end of the last increasing series.
- Should calibration be required in both directions, the series of readings are repeated in the opposite direction.
- The calibration data is then analysed to establish the following parameters.

Repeatability

The variation between the indicated deflection from series 1 and 2, expressed as a percentage of the mean of the two readings.

Reproducibility

The maximum variation between series 1, 2 and 3, or series 1, 2, 3, 4 and 5 expressed as a percentage of the mean indicated deflection calculated from series 1, 3 or series 1, 3, 4, and 5.

Error of Indication

Where the results are expressed in units of torque, the errors of indication are the variation between each applied torque and the mean indicated deflection at that torque.

Error of Zero Torque

The maximum zero reading recorded after each loading series is expressed as a percentage of the maximum mean indicated deflection.

Error of Interpolation

Where the results are expressed in volts or units other than torque units, a second order polynomial equation (best fit line) is established and the difference in deflection from the computed value is expressed as a percentage of the computed value.

Reversibility

The variation between the readings from the last torque series applied in an increasing mode and the readings for the same given torque applied in a decreasing mode. Reversibility is expressed as a percentage of the deflection of the last increasing series for the given torque.

Classification

- The parameters are each compared with a table to establish the device's classification. Class 0.05 is the highest performance, and class 5 is the lowest defined by the standard. The overall class reported will be that of the lowest performing parameter. For example reproducibility may be a class 1 when all other parameters meet class 0.5. The device will be classified as 1.
- Additionally the uncertainty of measurement of the applied torque must be five times better than the overall class reported. Norbar's uncertainty of measurement (typically 0.02%) allows classification to Class 0.1 devices.
- Different classes may be quoted for ranges below 20% of maximum capacity.

Relative Measurement Uncertainty Interval

The relative measurement uncertainty interval of the device is also calculated by combining the relative mean deviation with the relative expanded uncertainty.

Effectively the uncertainty interval encompasses all of a transducers reported errors and uncertainty of calibration, providing the user with a maximum error value of the calibrated device.

Accredited calibrations performed to BS 7882:2017 meet the requirements of BS EN ISO6789-2:2017 clause 4.3 and annex C 7.3, and BS EN ISO 6789-1:2017 clause 6.1.

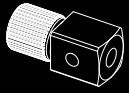

SPARES KITS

In order to maintain the quality, performance and peace of mind associated with our products Norbar recommend that only genuine Norbar spares are fitted to our products.

SERVICE REPLACEMENT POLICY

Our aim is to give you the fastest possible service when you send in a wrench for repair. Therefore, our policy is that all Norbar wrenches will, at Norbar's discretion, either be repaired or a 'service replacement' tool will be offered. This policy may be extended to wrenches from other manufacturers sent to Norbar for repair/replacement.

Repair

Where Norbar judges that a repair is viable, a combined repair and 'declaration of conformance' (COMBO) service will be offered – see page 130 for pricing. The setting of the wrench and documentation of the results will be carried out in conformance with ISO 6789-1:2017. For customers requiring a calibration certificate conforming to ISO 6789-2:2017 from Norbar's UKAS accredited laboratory, this service can also be offered at an additional cost.

Service Replacement

When Norbar judges that a repair is not commercially viable, a 'service replacement' tool will be offered. A 'service replacement' tool is manufactured from new parts, carries a twelve month warranty and is supplied with the same documentation as a new product of the equivalent type. For Professional, adjustable models from Model 15 to Model 1500 a calibration certificate conforming to ISO 6789-2:2017 will be supplied as standard from the production line. All other service replacement models, for example NorTorque® and TTi wrenches, will be supplied with a Declaration of Conformance to ISO 6789-1:2017. As with repairs, customers preferring a certificate from Norbar's UKAS accredited laboratory can specify this service at an additional cost.

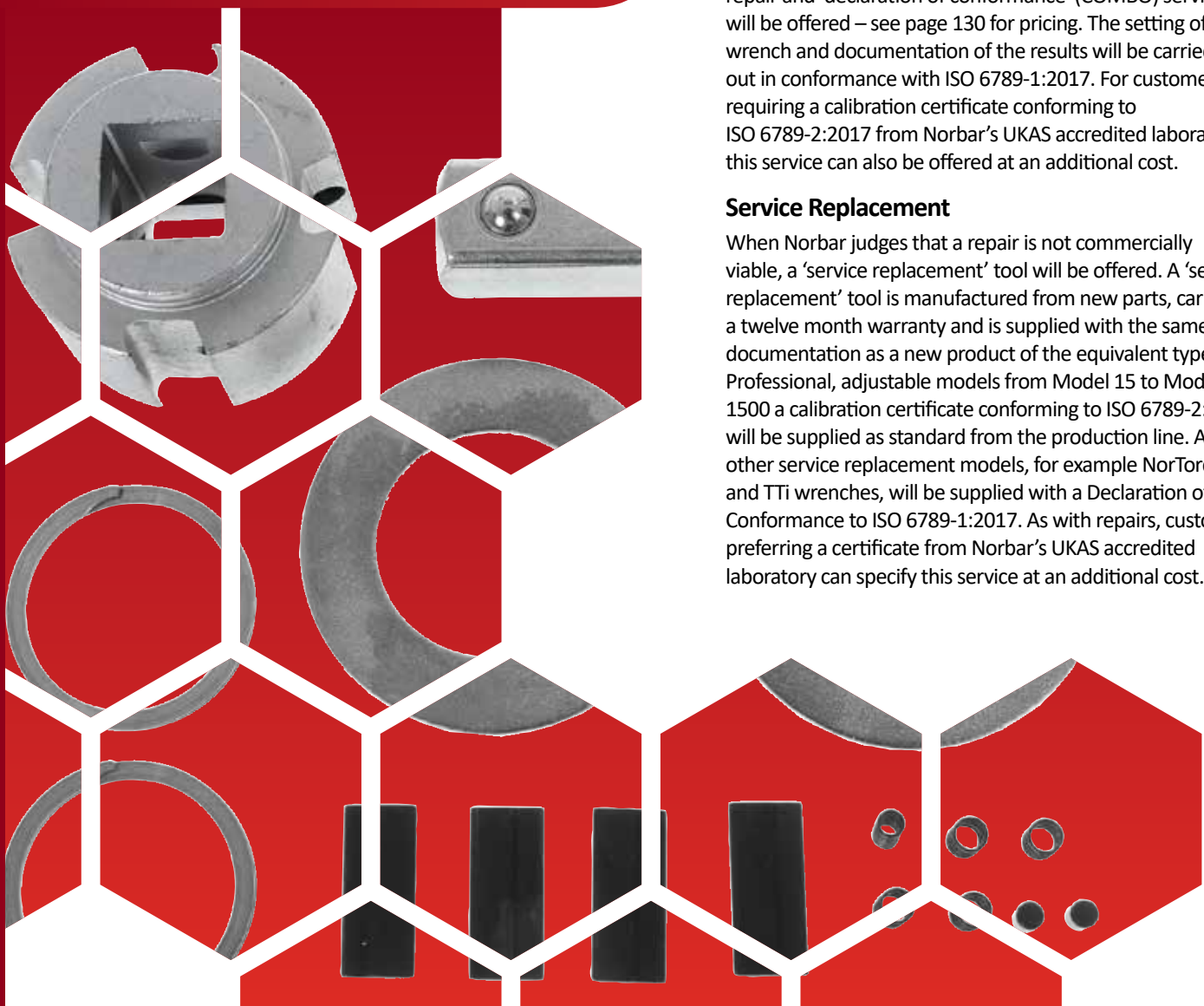

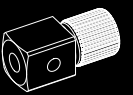

SPARES KITS

8	TORQUE SCREWDRIVER
13593.001NM	TTs Handle Repair Kit for 1.5 N-m Tool
13593.003NM	TTs Handle Repair Kit for 3.0 N-m Tool
13593.006NM	TTs Handle Repair Kit for 6.0 N-m Tool
13593.013LBI	TTs Handle Repair Kit for 13 lbf-in Tool
13593.026LBI	TTs Handle Repair Kit for 26 lbf-in Tool
13593.053LBI	TTs Handle Repair Kit for 53 lbf-in Tool
13593.P	TTs Handle Repair Kit for P Type Tool
13594	TTs Adjusting Screw & Retention Clip Repair Kit
13595	TTs Body Tube & Cam Assembly Repair Kit
13596	TTs End Knob Assembly Repair Kit
13597	TTs ¼" Blade Repair Kit
13609	TTs P Type Locking Knob Repair Kit

8	TT WRENCHES UP TO 50 N-m/35 lbf-ft
13425	¼" Ratchet Repair Kit, Mdl 20 N-m, 180 lbf-in
13426	⅜" Ratchet Repair Kit, Mdl 20 N-m, 180 lbf-in, 50 N-m, 35 lbf-ft
13427	½" Ratchet Repair Kit, Mdl 50 N-m, 35 lbf-ft
13636.020NLF	Handle Repair Kit, 20 N-m/lbf-in Scale
13636.020NM	Handle Repair Kit, 20 N-m Scale
13636.180LBI	Handle Repair Kit, 180 lbf-in Scale
13636.050NLF	Handle Repair Kit, 50 N-m/lbf-ft Scale
13636.050NM	Handle Repair Kit, 50 N-m Scale
13636.035LBF	Handle Repair Kit, 35 lbf-ft Scale
13417	Adjusting Knob Repair Kit
13637	Thrust Washer Repair Kit
11762	Rivet Repair Kit

8	TT WRENCHES 100 N-m/75 lbf-ft TO 300 N-m/250 lbf-ft
13410.100NLF	Handle Repair Kit, 100 N-m/lbf-ft Scale
13410.100NM	Handle Repair Kit, 100 N-m Scale
13410.075LBF	Handle Repair Kit, 75 lbf-ft Scale
13410.150NLF	Handle Repair Kit, 150 N-m/lbf-ft Scale
13410.150NM	Handle Repair Kit, 150 N-m Scale
13410.110LBF	Handle Repair Kit, 110 lbf-ft Scale
13410.200NLF	Handle Repair Kit, 200 N-m/lbf-ft Scale
13410.200NM	Handle Repair Kit, 200 N-m Scale
13410.150LBF	Handle Repair Kit, 150 lbf-ft Scale
13410.250NLF	Handle Repair Kit, 250 N-m/lbf-ft Scale
13410.250NM	Handle Repair Kit, 250 N-m Scale
13410.185LBF	Handle Repair Kit, 185 lbf-ft Scale
13410.300NLF	Handle Repair Kit, 300 N-m/lbf-ft Scale
13410.300NM	Handle Repair Kit, 300 N-m Scale
13410.220LBF	Handle Repair Kit, 220 lbf-ft Scale
13410.250LBF	Handle Repair Kit, 250 lbf-ft Scale

8	TT WRENCHES 100 N-m/75 lbf-ft TO 300 N-m/250 lbf-ft
13411	Adjusting Knob Repair Kit
13415	Thrust Washer Repair Kit
13414	Rivet Repair Kit

8	TTi WRENCHES
13693	TTi20 ¼" Ratchet Lever Arm Assemblies
13694	TTi20 ⅜" Ratchet Lever Arm Assemblies
13690	TTi50 ⅜" Ratchet Lever Arm Assemblies
13691	TTi50 ½" Ratchet Lever Arm Assemblies
13212	Ratchet Repair Kit, ⅜" sq. dr., 60/100
13214	Ratchet Repair Kit, ½" sq. dr., 200
13215	Ratchet Repair Kit, ½" sq. dr., Mdl 250/300 N-m, 185/220 lbf-ft
13491	Ratchet Replacement Kit, ⅜" sq. dr., 60/100
13492	Ratchet Replacement Kit, ½" sq. dr., 50 - 200
13493	Ratchet Replacement Kit, ½" sq. dr. Mdl 250/300 N-m, 185/220 lbf-ft)

For Handle Repair Kits please see TT section to the left.

8	TTfth WRENCHES
13695	TTfth20 9 x 12 mm Female End Repair Kit
13692	TTfth50 9 x 12 mm Female End Repair Kit

8	NON-MAGNETIC RATCHET REPAIR KITS
13769	Ratchet Repair Kit for 13900, 13902, 13904 & 13906
13770	Ratchet Repair Kit for 13901, 13903, 13905 & 13907

8	MODEL 5
13123	Spares Kit Model 5 Adjustable
13124	Calibration Kit Model 5 'P' Type

8	PROFESSIONAL TORQUE WRENCHES MODELS 60 - 400 (pre March 2015)
11598	'Automotive Ratchet' Repair Kit ⅜" Beta (Pro 60 & 100)
11618	'Automotive Ratchet' Repair Kit ½" Beta (Pro 60 & 100)
11622	'Automotive Ratchet' Repair Kit ½" Rev Beta (Pro 200 & 300)
11623	Push-Through Beta 72 Tooth Repair Kit ½"
13212	'Industrial Ratchet' Repair Kit ⅜" (Pro 60/100)
13213	'Industrial Ratchet' Repair Kit ½" (Pro 60/100)
13214	'Industrial Ratchet' Repair Kit ½" (Pro 200)
13215	'Industrial Ratchet' Repair Kit Mdl 300/330 ½" for 13047, 13049 & 13057
13216	'Industrial Ratchet' Repair Kit Pro 400 ¾" for 13050 & 13056
13190	Pro 400 ¾" sq. dr. to 17 mm Hex.
13235	Sq. Dr. Repair Kit ⅜" (Pro 60/100)
13236	Sq. Dr. Repair Kit ½" (Pro 60/100)
13237	Sq. Dr. Repair Kit ½" Pro 200/300/330
13157	Spares Kit Prof. Handle (post 1 st Jan 2001)

8	PROFESSIONAL TORQUE WRENCHES PRO 15 - 25 SPARES KITS
15395	'Automotive Ratchet' Repair Kit, ¼" sq. dr.
15396	'Automotive Ratchet' Repair Kit, ⅜" sq. dr.
15397.K	Handle Repair Kit
15398.K	Scale Mechanism Repair Kit
15399.K	Locking Knob Repair Kit
15400.K	Thrust Washer and Screw Kit
15401.K	Spring Repair Kit

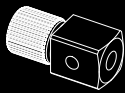

SPARES KITS

8	PROFESSIONAL TORQUE WRENCHES SPARES KITS
150100.K	Handle Repair Kit
150101.K	Scale Mechanism Repair Kit
150102.K	Locking Knob Repair Kit
150103.K	Thrust Washer and Screw Kit
150104.K	Spring Repair Kit
150105.K	½" sq. dr. Mushroom Kit
150106.K	¾" sq. dr. Mushroom Kit
150112.K	'Industrial Ratchet' Repair Kit, ¾" sq. dr. (Pro 50)
254100.PK	SKT Grub M5 x 8 LG Oval Point - Pack of 50
150113.K	'Industrial Ratchet' Repair Kit, ½" sq. dr. (Pro 100 - 200)
150114.K	'Industrial Ratchet' Repair Kit, ½" sq. dr. (Pro 300 - 340)
150115.K	'Industrial Ratchet' Repair Kit, ¾" sq. dr. (Pro 400)
11598	'Automotive Ratchet' Repair Kit ¾" sq. dr. (Pro 50 & 100)
11618	'Automotive Ratchet' Repair Kit ½" sq. dr. (Pro 50 & 100)
150111.K	'Automotive Ratchet' Repair Kit, ½" sq. dr. (Pro 200)

8	PROFESSIONAL TORQUE WRENCHES SPARES PACKS
10628.PK	Label TimeStrip - Pack of 50
10640.PK	TimeStrip Adhesive Gasket - Pack of 50
11521.PK	Shaped Washer - Pack of 20
11522.PK	End Stop - Pack of 10
15312.PK	End Cap - Pack of 25
25496.PK	SCR:SKT Grub M5 x 6 LG Oval - Pack of 50
25497.PK	SCR:SKT Grub M5 x 5 LG Dog Point - Pack of 50
254100.PK	SCR:SKT Grub M5 x 8 LG Oval Point - Pack of 50
25746.PK	M3 Dog Point Grub SCR - Pack of 50
25938.PK	Washer M4 STD.Flat - Pack of 100
26033.PK	Pivot Pin - Pack of 20
27029.PK	Steel Ball 3.8 mm Dia - Pack of 50
25351.10.PK	SHCS M4 x 10 LG - Pack of 50

8	CLICKTRONIC® TORQUE WRENCHES SPARES KITS
150104.K	Spring Repair Kit
150105.K	½" sq. dr. Mushroom Kit
150106.K	¾" sq. dr. Mushroom Kit
150107.K	Adjusting Screw and Wiper Kit
150108.K	Locking Knob Kit
150109.K	Lower Handle Kit
150110.K	Complete Handle Kit

8	CLICKTRONIC® TORQUE WRENCHES SPARES PACKS
10628.PK	Label TimeStrip - Pack of 50
10640.PK	TimeStrip Adhesive Gasket - Pack of 50
15524.PK	USB Bung - Pack of 5
39721.PK	Wiper 1 - 3 N - Pack of 5
25742.PK	M2.5 x 12 LG Torx Pan Screw - Pack of 80
25743.PK	M4 x 8 LG Torx CSK Screw - Pack of 50

8	PROFESSIONAL TORQUE WRENCHES MODELS 550 - 1500
14195	Ratchet Repair Kit Mdl 550/650 ¾"
14196	Ratchet Repair Kit Mdl 800/1000/1500 ¾"
14197	Ratchet Repair Kit Mdl 800/1000/1500 1"
14162	Ratchet Assembly Mdl 550/650
14163	Ratchet Assembly Mdl 1000
12297	Replacement Square Drive Mdl 550/650 ¾"
12299	Replacement Square Drive Mdl 550 1"
14157	Replacement Square Drive Mdl 800 - 1500 ¾"
14165	Replacement Square Drive Mdl 800 - 1500 1"
14185	Cover Kit for all Models
14218	Secondary Lever and Support Block Assy Upgrade kit for all Models pre 2004/169391
14217	Secondary Lever and Support Block Assy for all Models post 2004/169391
14220	Secondary Lever Assembly
14187	Screw Adjustable Kit for all Models
14166	Calibration Kit 'P' Type for all Models
13217	Replacement Professional Handle Kit
11807	Handle Spares Kit Professional 'P' Type
11698	Calibration Kit Professional 'P' Type
13242	Rivet Repair Kit

8	SLIMLINE TORQUE WRENCHES
11831	Ratchet Repair Kit SLO ¾" (post Jan 2008)
11832	Ratchet Repair Kit SLO ¾" (post Jan 2008)
11806	Spares Kit - SLO Adj Knob
11914	¾" sq.dr for SLO Fixed Head
11762	Rivet Repair Kit

8	INDUSTRIAL TORQUE WRENCHES
12307	Ratchet Repair Kit Industrial (except 6R & 6R-N)
12373	Ratchet Repair Kit (6R & 6R-N only)
12297	¾" Square Drive Assy for 3AR - 5AR & 3AR-N - 5AR-N
12299	1" Square Drive Assy for 3AR - 5AR & 3AR-N - 5AR-N
18492	1" Square Drive Assy for 6R & 6R-N
12374	1" Square Drive Repair Kit (6R & 6R-N only)
12355	Industrial Thrust Washer Spares Kit
12360	End Caps - Plastic 10 pack (Industrial)
12381	3AR Adjusting Nut
12382	No.4 Adjusting Nut
12383	4R Adjusting Nut
12384	4AR Adjusting Nut
12385	5R Adjusting Nut
12386	5AR Adjusting Nut
12387	6R Adjusting Nut
121094	5AR-N Adjusting Nut
121079	6R-N Adjusting Nut

In order for Norbar to supply the correct adjusting nut, we need to know the correct scale length for the tool being repaired. The scale length is denoted by a number on the nut being replaced and will be of the form e.g. 159/60.

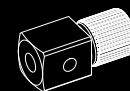

SPARES KITS

8 NORTORQUE TORQUE WRENCHES HANDLE KITS

130501.060NLF	Handle Repair Kit, 60 N-m/lbf-ft Scale
130501.060NM	Handle Repair Kit, 60 N-m Scale
130501.100NLF	Handle Repair Kit, 100 N-m/lbf-ft Scale
130501.100NM	Handle Repair Kit, 100 N-m Scale
130501.200NLF	Handle Repair Kit, 200 N-m/lbf-ft Scale
130501.200NM	Handle Repair Kit, 200 N-m Scale
130501.300NLF	Handle Repair Kit, 300 N-m/lbf-ft Scale
130501.300NM	Handle Repair Kit, 300 N-m Scale
130501.340NLF	Handle Repair Kit, 340 N-m/lbf-ft Scale
130501.340NM	Handle Repair Kit, 340 N-m Scale



13235 Repair Kit

8 NORTORQUE TORQUE WRENCHES SQUARE DRIVE REPAIR KITS

13235	Sq. Dr. Repair Kit 3/8" (Mdl60)
13236	Sq. Dr. Repair Kit 1/2" (Mdl100)
13237	Sq. Dr. Repair Kit 1/2" (Mdl200/300/340)



13212 Repair Kit

8 NORTORQUE TORQUE WRENCHES RATCHET REPAIR KITS

13212	Ratchet Repair Kit 3/8" (Mdl60)
13213	Ratchet Repair Kit 1/2" (Mdl100)
13214	Ratchet Repair Kit 1/2" (Mdl200)
13215	Ratchet Repair Kit 1/2" (Mdl300/340)

8 NORTORQUE TORQUE WRENCHES OTHER REPAIR KITS

130500.K	Locking Knob Kit
150103.K	Thrust Washer and Screw Kit



13215 Repair Kit

8 MULTIPLIER SPARES KIT

16831	Spares Kit No. 2 Output Carrier
16836	Spares Kit No. 5 Output Carrier
16832	Spares Kit No. 7 Output Carrier
16835	Spares Kit No. 9 Output Carrier
19348	HT3-1000 N-m Retention Pin
19349	HT3-1000 N-m Cranked Reaction
19347	HT3-1000 N-m Straight Reaction
77018.1	Sq. Drive HT3 3/4" (old style)
17185	Spares Kit HT3 3/4" Sq Dr (Pre May 1993 style with shoulder screw)
17676	Sq. Drive HT3 3/4" (to fit 17218, 17220 & all other models with square drive retained by rollpin)



77018.1

17676

17185

17223	Spares Kit HT3 Carriers
17225	Spares Kit HT3 3/4" Input Gear
18365	Spares Kit 72 mm Air Motor Handle
18544	Replacement 3/4" sq. dr., ET/EBT/PTS/PTM-52 Series
18545	Replacement 1" sq. dr., ET/EBT/PTS/PTM-52 Series
18779	Replacement 3/4" sq. dr., ET/EBT/PTS/PTM-72 Series
18492	Replacement 1" sq. dr., ET/EBT/PTS/PTM-72 Series
18221	Replacement 3/4" sq. dr., PT 72 Series
18220	Replacement 1" sq. dr., PT 72 Series
19260	Spares Kit for Fwd/Rev Gearbox Knob post Feb 2011 Tools
19077	Upgrade Kit for Fwd/Rev Gearbox for PTM

8 ET/EBT/PTS/PTM-92 & ET/EBT/PTS/PTM-119 SQUARE DRIVES

18934	1" for ET/EBT/PTS/PTM-92
18935	1 1/2" for ET/EBT/PTS/PTM-92
18959	1 1/2" for ET/EBT/PTS/PTM-119

8 VANE SETS FOR PNEUTORQUE MULTIPLIERS

18631	For PTM Series (Pack of 5)
18278	For PT 72 mm Series (Pack of 6)
16218	For PT Standard Series (Pack of 6)

8 SPARES FOR LUBRO CONTROL UNIT

28911	3 m Hose*
28912	6 m Hose*
28913	Pressure Gauge
28914	Filter Element for Filter/Regulator
28915	Bowl Assembly for Filter/Regulator
28916	Bowl Assembly for Lubricator
28917	Locking Collar
28918	1/2" BSP Taper Thread Adaptor

*Other lengths of hose are available, please contact Norbar for details.



CALIBRATION SERVICES

Declaration of Conformance	130
UKAS Accredited Calibration Certification	130
Other Certification	134
General Notes	134

A calibration 'priority booking' service is available, please contact the Customer Relations Department a minimum of one month prior to the required recalibration due date.

- Tel: +44 (0)1295 753635
- Fax: +44 (0)1295 753636
- Email: repairs@norbar.com

CALIBRATION SERVICES

Devices sent in for UKAS accredited calibration certification will be calibrated and the 'As Found' readings recorded. The calibration will be performed to the appropriate standard as specified in our schedule of accreditation.

- Should the device be in specification 'As Found', a certificate will be raised and the device returned.
- Should the device be out of specification, but capable of adjustment, it will be adjusted, 'As Left' readings taken, and one certificate raised with 'As Found' and 'As Left' readings on it.
- Should the device require repair that is not covered by a combined calibration and service, we will do so where possible, after consultation with the customer.

Norbar are accredited by UKAS for torque measurements between 0.005 N·m and 108,500 N·m or the imperial equivalents. Our Schedule of Accreditation gives further details (please refer to www.norbar.com).

UKAS accredited calibration certificates are issued under the authority of the United Kingdom Accreditation Service.

Norbar can calibrate non-Norbar Torque products, please contact us with the details of your equipment.



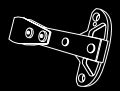

DECLARATION OF CONFORMANCE

TORQUE WRENCH DECLARATION OF CONFORMANCE (DOC)



ONE DIRECTION

DOC1.CW	Up to 400 N·m / 300 lbf·ft
DOC2.CW	Up to 1,000 N·m / 750 lbf·ft
DOC3.CW	Up to 1,500 N·m / 1,100 lbf·ft

ONE DIRECTION & REPAIR COMBO

RCDOC1.CW	NorTorque and Professional wrenches up to 400 N·m
RCDOC2.CW	Industrial wrenches 2R - 5R
RCDOC3.CW	Industrial wrench 5AR
RCDOC4.CW	Large Professional 550 & 650 N·m
RCDOC5.CW	Large Professional 800 - 1,500 N·m

TWO DIRECTIONS

DOC1.CW+CCW	Up to 400 N·m / 300 lbf·ft
DOC2.CW+CCW	Up to 1,000 N·m / 750 lbf·ft
DOC3.CW+CCW	Up to 1,500 N·m / 1,100 lbf·ft

TWO DIRECTIONS & REPAIR COMBO

RCDOC1.CW+CCW	NorTorque and Professional wrenches up to 400 N·m
RCDOC2.CW+CCW	Industrial wrenches 2R - 5R & 3AR-N - 5R-N
RCDOC3.CW+CCW	Industrial wrench 5AR & 5AR-N
RCDOC4.CW+CCW	Large Professional 550 & 650 N·m
RCDOC5.CW+CCW	Large Professional 800 - 1,500 N·m

UKAS ACCREDITED CALIBRATION CERTIFICATION

TORQUE WRENCH, UKAS ACCREDITED CALIBRATION CERTIFICATION

On receipt an 'As Found' calibration certificate will be carried out where possible. If the results do not fall within specification the wrench will be adjusted and if the adjustment does not bring the wrench back within specification then it will either be repaired or a service replacement will be offered – see page 125 for further details.

Calibration certificates are in accordance with the current standard for hand torque tools BS ISO 6789-2:2017. The certificate shows the nominal torque applied and the measured torque readings.

For guidance on Norbar's procedure for wrenches sent in for repair, see page 125. If the same tool is required to be returned, i.e. if you do not want the tool to be service replaced, then this should be made clear on the purchase order which accompanies the tool.

ONE DIRECTION

TWCC1.CW	Up to 400 N·m / 300 lbf·ft
TWCC2.CW	Up to 1,000 N·m / 750 lbf·ft
TWCC3.CW	Up to 3,000 N·m / 2,200 lbf·ft

TWO DIRECTIONS

TWCC1.CW+CCW	Up to 400 N·m / 300 lbf·ft
TWCC2.CW+CCW	Up to 1,000 N·m / 750 lbf·ft
TWCC3.CW+CCW	Up to 3,000 N·m / 2,200 lbf·ft

NORTRONIC UKAS ACCREDITED CALIBRATION CERTIFICATION



ONE DIRECTION & ANGLE

NTCC1.CW	NorTronic all sizes
----------	---------------------

TWO DIRECTIONS & ANGLE

NTCC1.CW+CCW	NorTronic all sizes
--------------	---------------------

MANUAL TORQUE MULTIPLYING GEARBOXES, UKAS ACCREDITED CALIBRATION CERTIFICATION



The part numbers shown below are for Certification 'As Found',

ONE DIRECTION

HTCC1.CW	Up to 6,000 N·m / 5,000 lbf·ft
----------	--------------------------------

TWO DIRECTIONS

HTCC1.CW+CCW	Up to 6,000 N·m / 5,000 lbf·ft
--------------	--------------------------------



UKAS ACCREDITED CALIBRATION CERTIFICATION

ELECTRONIC DEVICES

In accordance with the current standards for calibration of torque measurement devices, it is desirable to calibrate transducers with the display that is normally used. In this case the 'system' is calibrated. If it is not possible to supply the display unit, an equivalent calibrated display unit from the laboratory will be used. The calibration will then be valid for the transducer with the original display as long as the original display has been calibrated within the last 12 months.

Calibration certificates are in accordance with the current standard for torque measuring devices BS 7882:2017, and show the nominal torque applied, and the measured torque readings. Measured readings may be given in mV/V on request. Details of the standard are available on request.

It is not our intention to offer a full repair service for torque devices from other manufacturers. Where a device is in need of repair, the customer is advised to have this performed by an approved service agent or the manufacturer before submitting the device for UKAS accredited calibration. Some electronic transducer systems from other manufacturers may incur an additional calibration cost; the electronics department repair technicians will clarify this point if required. Occasionally it will be necessary to manufacture special adaptors to enable the calibration to be performed. This will of course affect the price and delivery, and will be discussed with the customer as the need arises.

CALIBRATION TO BS7882:2017 CLASS 0.1

Norbar's UKAS accredited laboratory performs standard calibrations on torque measuring devices to BS 7882:2017 class 0.2 increasing torques only. However the laboratory is able to calibrate devices to class 0.1 at the customer's request. Class 0.1 requires calibration in four different mounting positions each rotated 90° about the measurement axis. Classification to class 0.1 is dependent on the devices performance. Calibrations including a decreasing series of torques can also be provided if required. A price for these services is available on request.

This section contains combined calibration and service fixed details for Norbar products. Other manufacturers' equipment will be handled by individual quotation. Provided that the product is in serviceable condition*, we guarantee to carry out all calibration, function checks and repair work in order to bring the equipment back to its original functionality.

*Product would be regarded as unserviceable if either it or the components required for the repair are obsolete or unavailable. Serviceability also implies that the product is capable of repair without complete replacement.

Service replacements are available for some products.

ELECTRONIC TORQUE TRANSDUCERS, UKAS ACCREDITED CALIBRATION CERTIFICATION (WITH SQUARE DRIVE, FLANGE MOUNTED & PRE 2004 ROTARY)



The part numbers shown below are for Combined Calibration and Service, 'As Found' and 'As Left'

ONE DIRECTION

TDCCS1.CW	Up to 1,500 N·m / 1,000 lbf-ft
TDCCS5.CW®	From 1,501 to 7,000 N·m / 1,001 - 5,000 lbf-ft
TDCCS3.CW*	Square/Splined Drive From 7,001 to 100,000 N·m / 5,001 to 100,000 lbf-ft
TDCCS4.CW*	Flange Drive From 7,001 to 100,000 N·m / 5,001 to 100,000 lbf-ft
ADDCALPOINTS.CCS	Additional calibration steps below 10% of rated capacity to 2% for transducers up to 7,000 N·m (5,000 lbf-ft)

TWO DIRECTIONS

TDCCS1.CW+CCW	Up to 1,500 N·m / 1,000 lbf-ft
TDCCS5.CW+CCW®	From 1,501 to 7,000 N·m / 1,001 - 5,000 lbf-ft
TDCCS3.CW+CCW*	Square/Splined Drive From 7,001 to 100,000 N·m / 5,001 to 100,000 lbf-ft
TDCCS4.CW+CCW*	Flange Drive From 7,001 to 100,000 N·m / 5,001 to 100,000 lbf-ft

@ UKAS accredited calibration up to 6,000 N·m. A non-accredited value at 7,000 N·m is extrapolated and provided for reference only.

+ UKAS accredited calibration up to 80,000 lbf-ft. A non-accredited value at 100,000 lbf-ft is extrapolated and provided for reference only.

For part numbers TDCCS3.CW and TDCCS4.CW, static transducers with 2½" square drives and annular transducers to fit HT/PT 9 & HT/PT 11, a secondary calibration to extend the range below 10% of the rated capacity may be ordered using part number TDCCS5.CW

For part numbers TDCCS3.CW+CCW and TDCCS4.CW+CCW, static transducers with 2½" square drives and annular transducers to fit HT/PT 9 & HT/PT 11, a secondary calibration to extend the range below 10% of the rated capacity may be ordered using part number TDCCS5.CW+CCW

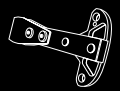

UKAS ACCREDITED CALIBRATION CERTIFICATION

ROTARY TRANSDUCERS (2004 ONWARDS), UKAS ACCREDITED CALIBRATION CERTIFICATION (PART CODE 50708.XXX-50724.XXX)



The part numbers shown below are for combined calibration and service, 'As Found' and 'As Left'

ONE DIRECTION

TDCCS2.CW	Up to 1,500 N·m / 1,000 lbf-ft
-----------	--------------------------------

TWO DIRECTIONS

TDCCS2.CW+CCW	Up to 1,500 N·m / 1,000 lbf-ft
---------------	--------------------------------

TRUCHECK VERSIONS 1 & 2



The part numbers shown below are for combined calibration and service, 'As Found' and 'As Left'

ONE DIRECTION

TCCCS1.CW	TruCheck versions 1 & 2 All Sizes (UKAS Accredited Calibration Certification)
TCCCS2.CW	TruCheck versions 1 & 2 All Sizes *

TWO DIRECTIONS

TCCCS1.CW+CCW	TruCheck versions 1 & 2 All Sizes (UKAS Accredited Calibration Certification)
---------------	---

*Issued with traceable certification.

PRO-TEST, UKAS ACCREDITED CALIBRATION CERTIFICATION



The part numbers shown below are for combined calibration and service, 'As Found' and 'As Left'

ONE DIRECTION

PROCCS.CW	Pro-Test All sizes
-----------	--------------------

TWO DIRECTIONS

PROCCS.CW+CCW	Pro-Test All Sizes
---------------	--------------------

PRO-LOG, TTT, T-BOX, T-BOX XL, T-BOX 2 & TTL-HE, UKAS ACCREDITED CALIBRATION CERTIFICATION



The part numbers shown below are for combined calibration and service, 'As Found' and 'As Left'

ONE DIRECTION

INSTCCS3.CW	Pro-Log or TTT
-------------	----------------

TWO DIRECTIONS

INSTCCS3.CW+CCW	Pro-Log or TTT
INSTCCS4.CW+CCW	TTL-HE, T-Box, T-Box XL or TWC Auto Control Box
INSTCCS5.CW+CCW	T-Box 2

TST, UKAS ACCREDITED CALIBRATION CERTIFICATION



The part numbers shown below are for combined calibration and service, 'As Found' and 'As Left' This includes both an instrument and system calibration

ONE DIRECTION

TSTCCS.CW	TST
-----------	-----

TWO DIRECTIONS

TSTCCS.CW+CCW	TST
---------------	-----

Section with combined calibration & service ends here

CALIBRATION BEAMS & WEIGHTS, UKAS ACCREDITED CALIBRATION CERTIFICATION



The part numbers shown below are for Length Certification, 'As Found' and 'As Left'

CBLC1	Disc or Beam up to 150 N·m / 100 lbf-ft
CBLC2	Disc or Beam up to 1,500 N·m / 1,000 lbf-ft
CBLC3*	Disc or Beam up to 6,800 N·m / 5,000 lbf-ft
WEIGHT.CC1	Calibration of Weights up to 25 kgf / 245 N / 55 lbf



UKAS ACCREDITED CALIBRATION CERTIFICATION

MECHANICAL TORQUE TESTING DEVICES, UKAS ACCREDITED CALIBRATION CERTIFICATION



The part numbers shown below are for combined calibration and service, 'As Found' and 'As Left'

ONE DIRECTION

MCCS1.CW | Up to 5,000 N·m / 5,000 lbf-ft

TWO DIRECTIONS

MCCS1.CW+CCW | Up to 5,000 N·m / 5,000 lbf-ft

TWA, UKAS ACCREDITED CALIBRATION CERTIFICATION



The part numbers shown below are for Combined Calibration and Service, 'As Found' and 'As Left'

ONE DIRECTION

TWACCS.CW | TWA All Sizes

TWO DIRECTIONS

TWACCS.CW+CCW | TWA All Sizes

ETS, UKAS ACCREDITED CALIBRATION CERTIFICATION



The part numbers shown below are for combined calibration and service, 'As Found' and 'As Left'

INSTCCS1.CW | ETS

DTS, UKAS ACCREDITED CALIBRATION CERTIFICATION



ONE DIRECTION

DTSCCS1.CW [@]	DTS up to 7,000 N·m or 5,000 lbf-ft
DTSCCS2.CW ⁺	DTS from 7,001 to 100,000 N·m / 5,001 to 100,000 lbf-ft Square and Spline drive
DTSCCS3.CW ⁺	DTS from 7,001 to 100,000 N·m / 5,001 to 100,000 lbf-ft Flange drive

TWO DIRECTIONS

DTSCCS1.CW+CCW [@]	DTS up to 7,000 N·m or 5,000 lbf-ft
DTSCCS2.CW+CCW ⁺	DTS from 7,001 to 100,000 N·m / 5,001 to 100,000 lbf-ft Square and Spline drive
DTSCCS3.CW+CCW ⁺	DTS from 7,001 to 100,000 N·m / 5,001 to 100,000 lbf-ft Flange drive

- @ UKAS accredited calibration up to 6,000 N·m. A non-accredited value at 7,000 N·m is extrapolated and provided for reference only.
- + UKAS accredited calibration up to 80,000 lbf-ft. A non-accredited value at 100,000 lbf-ft is extrapolated and provided for reference only.

ETTA, UKAS ACCREDITED CALIBRATION CERTIFICATION



The part numbers shown below are for combined calibration and service, 'As Found' and 'As Left'

ETTACCS.CW | ETTA

GENERAL DEVICES, UKAS ACCREDITED CALIBRATION CERTIFICATION

EMCC | Mechanical Enclosure Meter Calibration (CW + CCW)



OTHER CERTIFICATION

EVOTORQUE AND PNEUTORQUE CERTIFICATES



These devices are outside the scheduled accreditation issued by UKAS.

HTCERT	Compact Series Calibration
PTCERT	PneuTorque Calibration
PTICEC	PTM IC/EC Certificate of air pressure vs torque
ETCERT	EvoTorque 1, 2 & EBT Certificate of torque and angle

USM CERTIFICATES



These devices are outside the scheduled accreditation issued by UKAS.

USMCC	Ultrasonic Stress Meter certificate of calibration
-------	--

GENERAL DEVICES

These devices are outside the scheduled accreditation issued by UKAS.

Weight Set Certificates accredited by UKAS or other certified bodies

ETSDPFT	ETS Data Printer. Function Test
ETSBPUFT	ETS Battery Power Unit. Function Test
FWSUFT	ETS or ETTA 5 Way Switch Unit. Function Test
TWSUFT	ETS or ETTA 2 Way Switch Unit. Function Test

TRANSDUCER CONVERSIONS

SQ8888	ETS Transducer conversion to Smart Transducer (does not include calibration)
SQ2005	ETTA Transducer conversion to Smart Transducer (does not include calibration)

GLOBAL SERVICE

Norbar is the only torque equipment manufacturer capable of offering tool and instrument calibration services to the original factory standard on four continents.



NORBAR TORQUE TOOLS LTD
 Wildmere Road, Banbury,
 Oxfordshire, OX16 3JU
 UNITED KINGDOM
 Tel + 44 (0)1295 753600
 Email sales@norbar.com



NORBAR TORQUE TOOLS
 45-47 Raglan Avenue,
 Edwardstown, SA 5039
 AUSTRALIA
 Tel + 61 (0)8 8292 9777
 Email enquiry@norbar.com.au



NORBAR TORQUE TOOLS INC
 36400 Biltmore Place,
 Willoughby, Ohio 44094
 USA
 Tel + 1 866 667 2272
 Email inquiry@norbar.us



NORBAR TORQUE TOOLS PTE LTD
 194 Pandan Loop,
 #07-20 Pantech Business Hub,
 SINGAPORE 128383
 Tel + 65 6841 1371
 Email enquires@norbar.sg



NORBAR TORQUE TOOLS (SHANGHAI) LTD
 7/F, Building 91, No. 1122,
 Qinzhou North Road
 Xuhui District, Shanghai
 CHINA 200233
 Tel + 86 21 6145 0368
 Email sales@norbar.com.cn



NORBAR TORQUE TOOLS INDIA PVT. LTD
 Plot No A – 168 Khairne Industrial Area
 Thane Belapur Road
 Mahape Navi Mumbai – 400 709
 INDIA
 Tel + 91 22 2778 8480
 Email enquiry@norbar.in



Accredited laboratories in Australia, USA, Singapore, China and India operate the same equipment and procedures as the UKAS accredited laboratory within our headquarters in the UK.



1. INTERPRETATION AND APPLICATION OF TERMS

1.1 In these Conditions the following words have the following meanings:

“Contract”	means the contract between Norbar and the Customer for the sale and purchase of the Goods and/or Services, incorporating these Conditions, the Order and the Order Acknowledgement;
“Customer”	means the person(s), firm or company who purchases Goods and/or Services from Norbar;
“Customer Equipment”	means equipment belonging to the Customer which is the subject of Services to be carried out under a Contract;
“Delivery Point”	means the address within the UK mainland which is notified to Norbar as the place for delivery of the Goods and/or Customer Equipment;
“Engineer to Order Goods”	means any non-standard Goods specifically designed, modified and/or made for the Customer or to the Customer’s specification;
“Goods”	means the goods set out in the Order to be supplied by Norbar to the Customer (including any part or parts of them);
“Norbar”	means Norbar Torque Tools Limited (380480), whose registered office address is at Wildmere Road, Banbury, Oxon, OX16 3JU;
“Order”	means the order for the Goods and/or Services placed on Norbar by the Customer;
“Order Acknowledgement”	means the acknowledgement of Order issued by Norbar to the Customer;
“Services”	means the services set out in the Order to be performed by Norbar for the Customer.

- 1.2 Subject to any variation under Condition 1.4 the Contract will be on these Conditions, the Order and the Order Acknowledgement to the exclusion of all other terms and conditions. They supersede any previously issued terms and conditions of supply. If there is any discrepancy between these Conditions, the Order and the Order Acknowledgement, the latter will prevail to the extent necessary to resolve the inconsistency.
- 1.3 No terms or conditions endorsed upon, delivered with or contained in the Customer’s Order, confirmation of order, specification or other document will form part of the Contract.
- 1.4 These Conditions apply to all of Norbar’s sales and any variation to these Conditions and any representations about the Goods and/or Services will have no effect unless expressly agreed in writing and signed by an authorised representative of Norbar. The Customer acknowledges that it has not relied on and will have no remedy in respect of any statement, promise or representation made or given by or on behalf of Norbar which is not set out in the Contract. Nothing in this Condition will exclude or limit Norbar’s liability for fraudulent misrepresentation.
- 1.5 Each Order or acceptance of a quotation for Goods or Services by the Customer from Norbar will be deemed to be an offer by the Customer to purchase Goods and/or Services subject to these Conditions and no Order will be deemed to be accepted by Norbar until a written Order Acknowledgement is issued by Norbar or Norbar delivers the Goods and/or Services to the Customer, whichever occurs first.
- 1.6 Any quotation is given on the basis that no Contract will come into existence until Norbar despatches an Order Acknowledgement or delivers the Goods and/or Services to the Customer. Any quotation is valid for a period of 30 days only from its date, provided that Norbar has not previously withdrawn or amended it.

2 DESCRIPTION

- 2.1 The description of the Goods will be as set out in Norbar’s catalogue or other published specification current at the time that the relevant Order is accepted by Norbar or, in the case of Services and Engineer to Order Goods, as specified in the relevant quotation or Order Acknowledgement. If there is any inconsistency between the published specification, the quotation and the Order Acknowledgement, the Order Acknowledgement will take precedence over the quotation which will take precedence over the published specification to the extent necessary to resolve the inconsistency.
- 2.2 Norbar reserves the right to make any changes to the specification of the Goods (including Engineer to Order Goods) and/or Services which are required to conform with any applicable statutory or regulatory requirements or which do not materially affect their quality or performance. The Customer will not be permitted to reject Goods and/or Services and Norbar will have no liability to the Customer in respect of any failure of the Goods and/or Services to comply with any specification in these circumstances.
- 2.3 The Customer acknowledges that all intellectual property rights in the Goods (including Engineer to Order Goods) and in any novel combinations or applications of the Goods (whether as a kit, system or otherwise) or which arise in the course of conducting the Services belong solely to Norbar and, to the extent that any such rights do not automatically vest in Norbar by operation of law, hereby assigns to Norbar all such rights. The Customer will take any action and execute any document reasonably required by Norbar to give full effect to this Condition.

3 DELIVERY

- 3.1 In the case of sales of Goods within the UK mainland, delivery will take place:
- if the Goods are to be collected, on delivery to the Customer or to the Customer’s named carrier at Norbar’s premises at Wildmere Road, Banbury, Oxon OX16 3JU; and
 - in all other cases, on delivery to the Delivery Point.
- In the case of sales outside the UK mainland (including non-mainland UK) sales will be delivered FCA Norbar’s premises at Wildmere Road, Banbury, Oxon OX16 3JU (INCOTERMS 2020 edition), except where otherwise agreed in writing.
- 3.2 All Services will be performed at Norbar’s premises at Wildmere Road, Banbury, Oxon OX16 3JU unless otherwise agreed in writing and the Services will be deemed to be performed on completion of the performance of the Services as specified in the Order Acknowledgement.
- 3.3 Any dates specified by Norbar for delivery of the Goods or performance of the Services are intended to be an estimate and time for delivery will not be made of the essence by notice. If no dates are so specified, delivery will be within a reasonable time. The Goods and/or Services may be delivered by instalments.

- 3.4 If for any reason the Customer will not accept delivery of any of the Goods when they are ready for delivery, or Norbar is unable to deliver the Goods on time because the Customer has not provided appropriate instructions, documents, licences or authorisations then, without prejudice to any other right or remedy available to Norbar:
- risk in the Goods will pass to the Customer;
 - the Goods will be deemed to have been delivered; and
 - Norbar may store the Goods until delivery whereupon the Customer will be liable for all related costs and expenses (including, without limitation, storage and insurance).
- 3.5 Norbar may, at its discretion, accept returns of Goods ordered in error or no longer required, subject to the payment of a handling charge of 15% of the order value (excluding VAT), except that:
- Production ‘P’ type wrenches will not be accepted for return;
 - Goods supplied with a UKAS accredited calibration certificate will be subject to a recalibration charge in addition to the handling charge;
 - Engineer to Order Goods may be charged for up to 100% of full price.
- Goods returned for credit will only be accepted if they are returned in the original packaging, in a new, unused condition, carriage paid within 30 days after the despatch date.

4 NON DELIVERY

- 4.1 The quantity of any consignment of Goods as recorded by Norbar upon despatch from Norbar’s place of business will be conclusive evidence of the quantity received by the Customer on delivery unless the Customer can provide conclusive evidence proving the contrary.
- 4.2 Norbar will not be liable for any non delivery of Goods (even if caused by Norbar’s negligence) unless written notice is given to Norbar within 14 days of the date when the Goods would, in the ordinary course of events, have been received.
- 4.3 Any liability of Norbar for non delivery of the Goods will be limited to replacing the Goods within a reasonable time or issuing a credit note at the pro rata Contract rate against any invoice raised for such Goods.

5 RISK/TITLE

- 5.1 The Goods are at the risk of the Customer from the time of delivery.
- 5.2 Ownership of the Goods will not pass to the Customer until Norbar has received in full (in cash or cleared funds) all sums due to it in respect of the Goods and all other sums which are or which become due to Norbar from the Customer on any account.
- 5.3 Until ownership of the Goods has passed to the Customer, the Customer will hold all Goods on a fiduciary basis as Norbar’s bailee and Norbar will be entitled at any time:
- to require (at no cost to Norbar) that the Goods are stored separately and clearly marked in such a way that they will readily be seen to be the property of Norbar; and/or
 - to require the Customer to deliver up the Goods or any part of them to Norbar and if the Customer refuses to do so, to immediately repossess them; and/or
 - to enter any premises or vehicle (by its employees or agents and in the case of premises, with or without vehicles) where Goods still owned by Norbar are stored or reasonably thought to be stored in order to inspect and/or repossess them.
- 5.4 Norbar will be entitled to recover payment for the Goods ordered notwithstanding that ownership of the Goods has not passed from Norbar.
- 5.5 The Customer may resell the Goods before ownership has passed to it providing that any such sale is made in the ordinary course of its business at full market value and the Customer is not aware that an event specified in Condition 5.6(a) has occurred or is likely to occur.
- 5.6 Until ownership of the Goods has passed to the Customer, the Customer’s right to possession of the Goods will terminate immediately if:
- the Customer is made bankrupt or petitions for its own bankruptcy, or has a receiver, administrative receiver or administrator appointed over all or any of its assets or undertaking or, other than for the purposes of a solvent amalgamation or reconstruction, enters into liquidation, enters into any composition or arrangement with or for the benefit of its creditors or ceases to carry on business; or
 - the Customer fails to observe or perform any of its obligations under the Contract or any other contract between Norbar and the Customer; or
 - the Customer encumbers or in any way charges any of the Goods.
- 5.7 Ownership of all Customer Equipment will remain the property of the Customer throughout the provision of the Services. Subject to Condition 6.2, Norbar will take reasonable care to safeguard the Customer Equipment and no less care than it takes to safeguard its own similar property.
- 5.8 On termination of the Contract for any reason, Norbar’s rights under this Condition 5 will remain in effect.

6 PRICE AND PAYMENT

- 6.1 Unless otherwise agreed by Norbar in writing the price for the Goods and/or Services will be the price set out in Norbar’s price list current as at the date of delivery of the Goods or performance of the Services or will be as set out in any quotation provided by Norbar.
- 6.2 The price given in the current Norbar price list for calibration and repair services or in any quotation for such Services is subject to the returned Customer Equipment being of serviceable condition. If the Customer Equipment is not of serviceable condition or is out of specification and cannot be adjusted or is uneconomic to repair, either a new quotation will be provided or a service replacement tool will be offered to the Customer. If the Customer does not accept the revised quotation or service replacement within 30 days, Norbar will re-quote, revising the costs as necessary. If after a further 30 days instructions have still not been received, Norbar may (at its option) either return the Customer Equipment and invoice for costs incurred or dispose of the Customer Equipment.
- 6.3 The price for the Goods and/or Services will be exclusive of any value added tax which the Customer will pay in addition when it is due to pay for the Goods and/or Services. The price for Goods and Services includes the cost



- of delivery (or return of Customer Equipment in the case of Services) if the order (i) is for delivery on Monday to Friday (inclusive) within the UK mainland to the Customer's usual Delivery Point using Norbar's usual delivery method and (ii) has a value of over £100.00 (excluding VAT). If delivery is to Northern Ireland, the price for Goods and Services includes the cost of delivery (or return of Customer Equipment in the case of Services) if the order (i) is for delivery on Monday to Friday (inclusive) to the Customer's usual Delivery Point using Norbar's usual delivery method and (ii) has a value of over £300.00 (excluding VAT). In all other cases, the cost of delivery of Goods or return of Customer Equipment will be charged in addition and will be due for payment at the same time as payment for the Goods is due.
- 6.4 If the Customer holds an account with Norbar, payment of the price for the Goods and/or Services is due within the agreed payment terms for that account. If any amount payable is not made within 30 days after the due date in accordance with the terms of the account, Norbar may withdraw credit facilities. If the Customer does not have an account with Norbar, or if credit facilities have been withdrawn from the Customer, payment is due either at the time the Order is placed or in accordance with any payment schedule set out in the quotation and may be tendered by cheque, credit card or bank transfer. In all cases, payment must be in pounds sterling (except where otherwise agreed in writing).
- 6.5 Time for payment will be of the essence.
- 6.6 No payment will be deemed to have been received until Norbar has received cleared funds.
- 6.7 All payments payable to Norbar under the Contract will become due immediately upon termination of this Contract notwithstanding any other Condition of the Contract or any other arrangement or agreement between the parties.
- 6.8 The Customer will make all payments due under the Contract without any deduction whether by way of set-off, counterclaim, discount, abatement or otherwise unless the Customer has a valid court order requiring an amount equal to such deduction to be paid by Norbar to the Customer.
- 6.9 If the Customer fails to pay Norbar any sum due pursuant to the Contract the Customer will be liable to pay interest to Norbar on such sum from the due date for payment at the annual rate of 4% above the base lending rate from time to time of Barclay's Bank plc, accruing on a daily basis until payment is made, whether before or after any judgment.
- 7. WARRANTY AND LIABILITY**
- 7.1 Norbar warrants that, subject to the other provisions of these Conditions upon delivery, and for a period of 12 months after the date of delivery, the Goods will:
- be of satisfactory quality within the meaning of the Sale of Goods Act 1979; and
 - comply in all material respects with the specification for them as set out in Norbar's catalogue or other published specification current at the time that the order for the Goods was accepted by Norbar.
- 7.2 Norbar warrants that, subject to the other provisions of these Conditions all Services will:
- be supplied with reasonable skill and care within the meaning of the Supply of Goods and Services Act 1982; and
 - conform in all material respects with the specification for them as set out in Norbar's catalogue or other published specification current at the time the order for the Services was accepted by Norbar (unless specifically varied in the quotation or Order Acknowledgement).
- 7.3 Norbar will not be liable for a breach of any of the warranties in Condition 7.1 unless:
- the Customer gives written notice of the defect to Norbar within 14 days of the time when the Customer discovers or ought to have discovered the defect; and
 - the Customer returns the defective Goods properly packed, carriage paid to Norbar's premises at the address given in Condition 1.1 or otherwise specified by Norbar.
- 7.4 Norbar will not be liable for a breach of the warranties in Condition 7.1 if:
- the Customer makes any further use of the Goods after giving notice of any defect; or
 - the Goods have been misused, mishandled, overloaded, amended, modified or repaired in any way by the Customer or its customers, or used for any purpose other than that for which they were designed; or
 - the defect is due to fair wear and tear or arises because the Goods have been subject to excessive use or used in an environment for which they were not designed; or
 - the Goods differ from their specification as a result of changes made to ensure they comply with applicable statutory or regulatory requirements; or
 - the Customer or its customer has failed to follow Norbar's oral or written instructions as to the storage, installation, commissioning, use, repair, calibration or maintenance of the Goods or (if there are no applicable instructions or standards) good trade or engineering practice.
- 7.5 Norbar will not be liable for a breach of the warranties in Condition 7.2 unless:
- the Customer gives written notice to Norbar identifying which Services are defective in sufficient detail within 14 days of the time when the Customer discovers or ought to have discovered the defect; and
 - if the claim relates to Customer Equipment, Norbar is given a reasonable opportunity to examine the Customer Equipment and to assess the claim of defective Services,
- 7.6 Subject to Conditions 7.3 and 7.4, if any of the Goods do not conform with any of the warranties in Condition 7.1, Norbar will at its option repair or replace such Goods (or the defective part of them) or refund the price of such Goods at the pro rata Contract rate. The provisions of these Conditions will apply to any Goods that are remedied or replaced.
- 7.7 Subject to Condition 7.5 if any of the Services do not conform with any of warranties in Condition 7.2, Norbar will at its option remedy, re-perform or refund the Services that do not comply at the pro rata Contract rate. The provisions of these Conditions will apply to any Services that are remedied or re-performed for a period of 90 days with effect from the date of performance of the remedied or re-performed Services. If any repair of Customer Equipment fails within 90 days after the date on which it was returned to the Customer by Norbar, Norbar will at its option remedy, re-perform or refund the Services that do not comply at the pro rata Contract rate.

- 7.8 If Norbar complies with Condition 7.6 or 7.7 (as applicable), it will have no further liability for a breach of any of the warranties in Condition 7.1 or 7.2 in respect of such Goods and/or Services.
- 7.9 Except as provided in Conditions 7.1 and 7.2, Norbar makes no representation or warranty, whether express or implied, as to the quality or fitness for purpose of the Goods or Services and all warranties, Conditions and other terms which may be implied by statute or common law are, to the fullest extent permitted by law, excluded from the Contract.
- 7.10 Nothing in this Contract excludes or limits the liability of Norbar for:
- death or personal injury caused by Norbar's negligence; or
 - defective products under the Consumer Protection Act 1987; or
 - for fraud or fraudulent misrepresentation; or
 - any matter for which it would be unlawful for Norbar to exclude or restrict liability.

THE CUSTOMER'S ATTENTION IS DRAWN TO THE PROVISIONS OF CONDITION 7.11

- 7.11 Subject to 7.10:
- Norbar's total liability in contract, tort (including negligence or breach of statutory duty), misrepresentation, restitution or otherwise arising in connection with the performance or contemplated performance of this Contract will be limited to the price of the Goods and/or Services; and
 - Norbar will not in any event be liable to the Customer for any loss of profit, loss of business or depletion of goodwill or loss of data, in each case whether direct, indirect or consequential, or any claims for consequential compensation whatsoever (howsoever caused) which arise out of or in connection with this Contract.
- 7.12 The Customer acknowledges that the price of the Goods and/or Services has been calculated on the basis that Norbar excludes and limits its liability in accordance with Condition 7.11.
- 7.13 Where the Goods and/or Services are sold under a consumer transaction the statutory rights of the Customer are not affected by these Conditions.

8. FORCE MAJEURE

Norbar reserves the right to defer the date of delivery or to cancel the Contract or reduce the volume of the Goods or Services ordered by the Customer (without liability to the Customer) if it is prevented from or delayed in the carrying on of its business due to circumstances beyond the reasonable control of Norbar including, without limitation, acts of God, governmental actions, war or national emergency, riot, civil commotion, fire, explosion, flood, epidemic, lock-outs, strikes or other labour disputes (whether or not relating to either party's workforce), or restraints or delays affecting carriers or inability or delay in obtaining supplies of adequate or suitable materials or components.

9. NOTICES

Any notice to be given under this Contract will be in writing and will be sent by first class mail within the UK, or by air mail; in the case of Norbar to the address set out in Condition 1.1 and in the case of the Customer to the Delivery Point or such other address or fax number as the Customer may from time to time notify to Norbar for this purpose in accordance with this Condition. Notices sent as above will be deemed to have been received three working days after the date of posting (in the case of mail within the UK), or seven working days after the date of posting (in the case of air mail).

10. ANTI-BRIBERY

- 10.1 Both Norbar and the Customer will comply with the United Kingdom Bribery Act 2010 and associated guidance and all other applicable United Kingdom legislation, statutory instruments and regulations in relation to bribery or corruption and similar or equivalent legislation in any other relevant jurisdiction.
- 10.2 Without limitation to clause 10.1, neither party shall make or receive any bribe (as defined in the Bribery Act 2010) or other improper payment or allow any such to be made or received on its behalf either in the United Kingdom or elsewhere and shall implement and maintain adequate procedures to ensure that such bribes or payments are not made or received directly or indirectly on its behalf.

11. GENERAL

- 11.1 The parties to the Contract do not intend that any term of the Contract will be enforceable by virtue of the Contracts (Rights of Third Parties) Act 1999 by any person that is not a party to it, except that any Affiliate of Norbar may directly enforce any term of the Contract where "Affiliate" means any entity that directly or indirectly Controls, is Controlled by or is under common control with Norbar and "Control" means ownership of more than 50% of the issued share capital of a company.
- 11.2 Each right or remedy of Norbar under the Contract is without prejudice to any other right or remedy of Norbar whether under the Contract or not.
- 11.3 If any provision of the Contract is found by any court, tribunal or administrative body of competent jurisdiction to be wholly or partly illegal, invalid, void, voidable or unenforceable it will to the extent of such illegality, invalidity, voidness, voidability or unenforceability be deemed severable and the remaining provisions of the Contract and the remainder of such provision will continue in full force and effect.
- 11.4 The Customer will not be entitled to assign the Contract or any part of it without the prior written consent of Norbar. Norbar may assign the Contract or any part of it or sub-contract any or all of its obligations under the Contract to any person, firm or company.
- 11.5 Failure or delay by Norbar in enforcing or partially enforcing any provision of the Contract will not be construed as a waiver of any of its rights under the Contract.
- 11.6 Any waiver by Norbar of any breach of, or any default under, any provision of the Contract by the Customer will not be deemed a waiver of any subsequent breach or default and will in no way affect the other terms of the Contract.
- 11.7 The formation, existence, construction, performance, validity and all aspects of the Contract will be governed by English law and the parties submit to the non-exclusive jurisdiction of the English courts.

2020 NORBAR SHUTDOWN PERIODS

THE FACTORY WILL BE CLOSED ON THE FOLLOWING DATES (INCLUSIVE)

Wednesday 1 st January - New Year's Day
Friday 10 th April to Monday 13 th April - Easter Bank Holiday
Friday 8 th May - Early May Bank Holiday
Monday 25 th May - Spring Bank Holiday
Monday 31 st August - Summer Bank Holiday
Friday 25 th December to Monday 4 th January 2021 - Christmas Shutdown

NORBAR PROMOTIONAL MATERIAL

CATALOGUES & LEAFLETS

07571	NorTorque® Sales Leaflet
07563	Professional Torque Wrench Sales Leaflet
07536	ClickTronic® Sales Leaflet
07594	Industrial Torque Wrench- New Generation Sales Leaflet
07436	NorTronic® Sales Leaflet
07579	HandTorque® HT3-1000 Sales Leaflet
07570	EvoTorque®2 Sales Leaflet
07591	EvoTorque® Battery Tool Sales Leaflet
07581	PneuTorque® PTS™ Sales Leaflet
07585	Right Angle Gearbox Sales Leaflet
07597	TruCheck™ 2 Sales Leaflet
07598	T-Box™ 2 Sales Leaflet
07589	TWC Sales Leaflet
07512	Aerospace Leaflet
07515	Energy Generation Leaflet
07510	Oil & Gas Leaflet

PROMOTIONAL ITEMS

07532	Norbar Torque Wrench Display Board Contact Norbar for slat wall adaptors
07539	Norbar Branded Pen
07551	Norbar Branded Pocket Notepad
07555	Norbar Branded Baseball Cap
07590	Norbar Branded Beanie Hat
07587	Norbar Branded USB Stick
07573	Norbar Branded Construction Pen
07574	Norbar Branded 2 Ring White Ring Binder
07576	Norbar Branded Screen Saver Cloth / Mouse Mat

DRILCO

CUSTOMER RELATIONS

OFFICE OPENING HOURS

Monday - Thursday	07:30 - 17:30
Friday	07:30 - 16:15

CONTACT DETAILS

New Sales
Direct Tel +44 (0)1295 753600
Email sales@norbar.com

NORBAR PRODUCT PORTFOLIO



Torque Screwdrivers



Torque Wrenches



Electronic Torque Wrenches



Manual Torque Multipliers



Pneumatic Torque Tools



Electronic Torque Tools



Battery Torque Tools



Torque Measurement Instruments



Torque Transducers



Calibration Services

NORBAR SOCIAL MEDIA



@voiceoftorque



www.norbar.com/news-events/blog



Norbar Torque Tools Ltd



Norbar Torque Tools



Norbar Torque



Norbar Torque Tools Ltd



Let's Talk

The live chat feature can be found at the bottom right of any page on our website

Norbar Torque Tools Ltd
Wildmere Road, Banbury
Oxfordshire, OX16 3JU
UNITED KINGDOM
www.norbar.com

After Sales Service
+44 (0)1295 753635
repairs@norbar.com